

# ASSEMBLY INSTRUCTIONS FOR SLIDING DOOR CUPBOARD

- \* PLEASE STUDY THE ASSEMBLY INSTRUCTIONS CAREFULLY & FAMILIARISE YOURSELF WITH THE PARTS BEFORE ASSEMBLY
- \* TOOLS REQUIRED : SCREW DRIVER, POP RIVET MACHINE & SOFT HAMMER.
- \* ENSURE THAT ALL THE ITEMS LISTED IN PART LIST ARE PRESENT BEFORE ASSEMBLY.

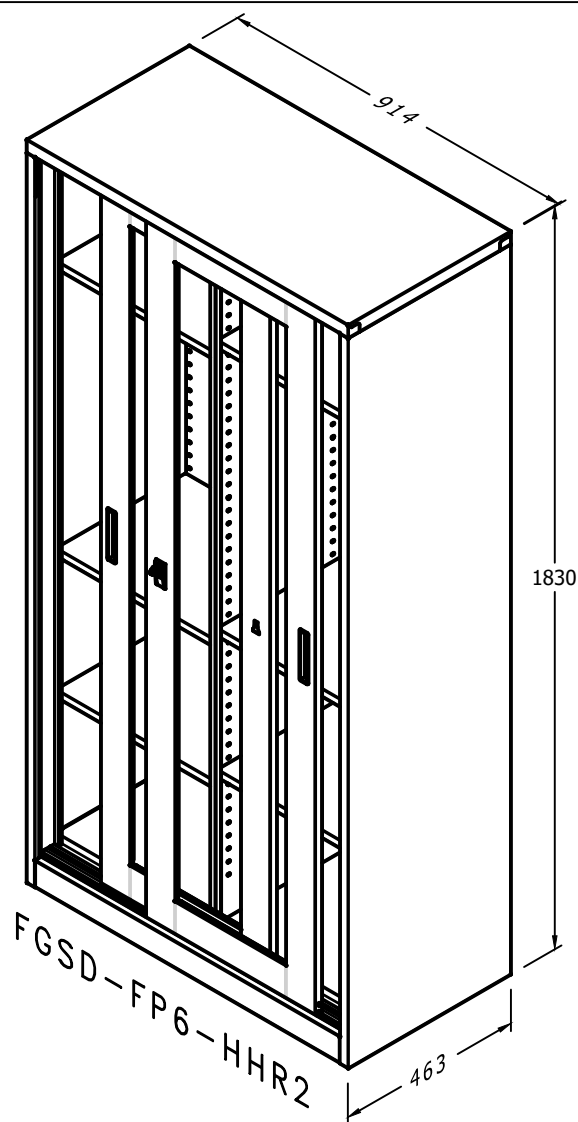
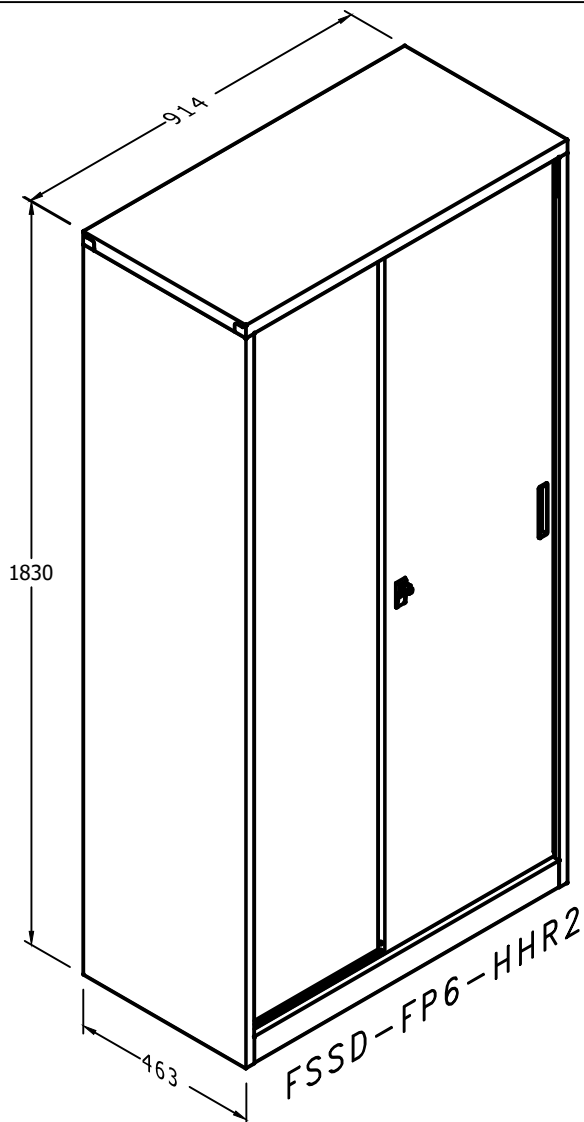

## LIST OF PARTS

Part No.	DESCRIPTION	Qty.
1	BACK RH	1
2	BACK LH	1
3	TOP PANEL	1
4	'L' PIECE	4
5	SIDE PANEL RH	1
6	SIDE PANEL LH	1
7	KICK PLATE	1
8	BOTTOM CORNER PIECE	4
9	POP RIVET	12
10	BOTTOM PANEL	1
11	PARTITION PANEL	1
12	STEEL HANGER ROD	2
13	SHELF SUPPORT BRACKET	24
14	HALF SHELF	6
15	DOOR ASSEMBLY LH (Gl/St)	1
16	DOOR ASSEMBLY RH (Gl/St)	1
17	SDU LOCK	1
18	TOP ROLLER 2 NOS. / DOOR	4
19	BOTTOM ROLLER 2 NOS. / DOOR	4
20	BANGER 4 NOS. / DOOR	8

Part No. 4

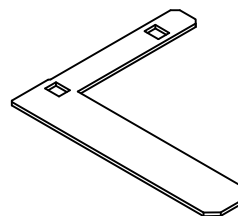

Part No. 9

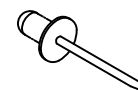

Part No. 8

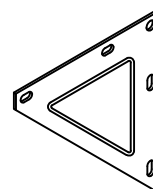

Part No. 15



STEP: 1 BACK PANEL RH&LH JOINING

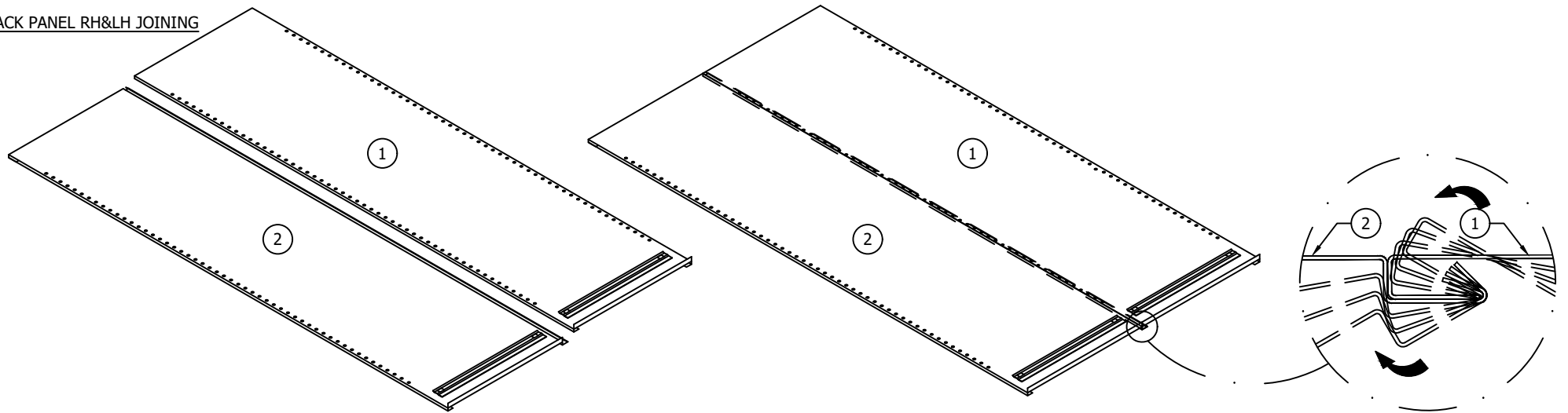

STEP: 2 TOP PANEL INSERTION

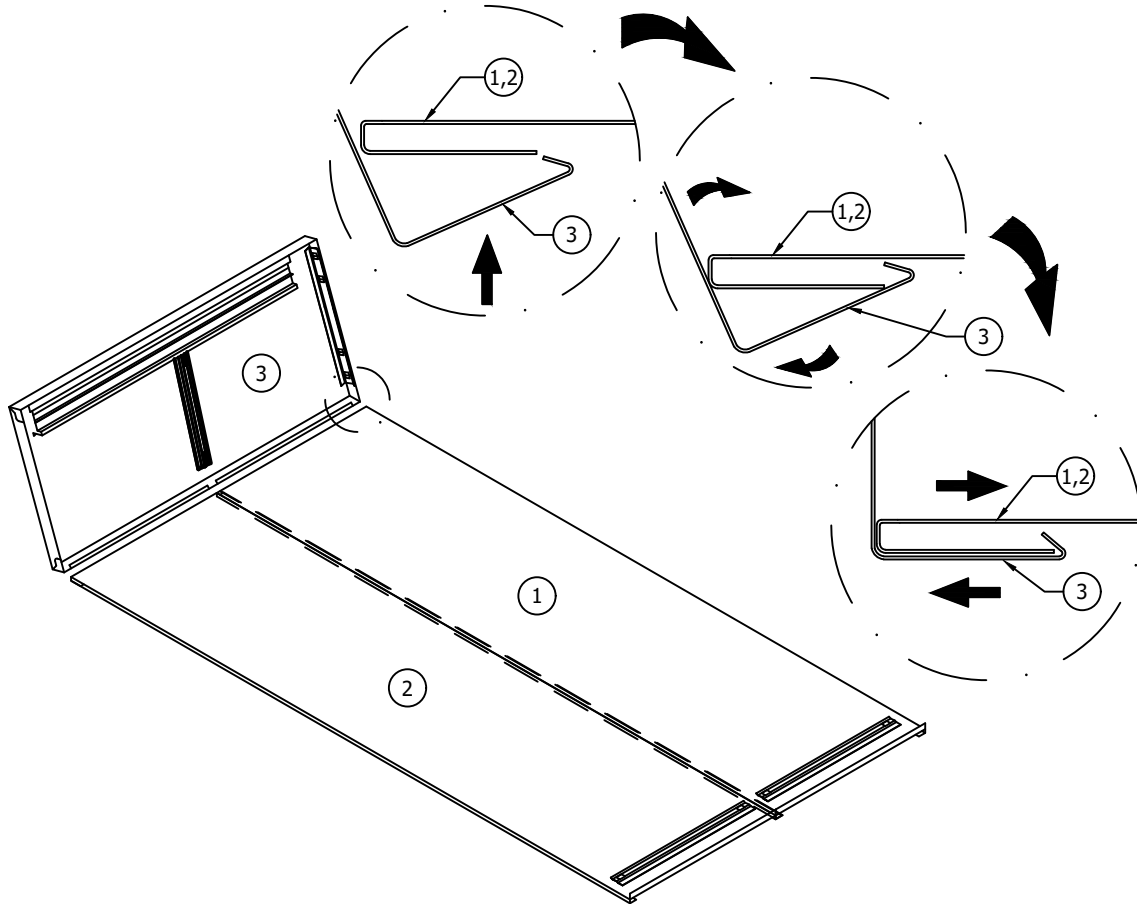

STEP: 3 LOCATING THE 'L' PIECE IN THE TOP PANEL

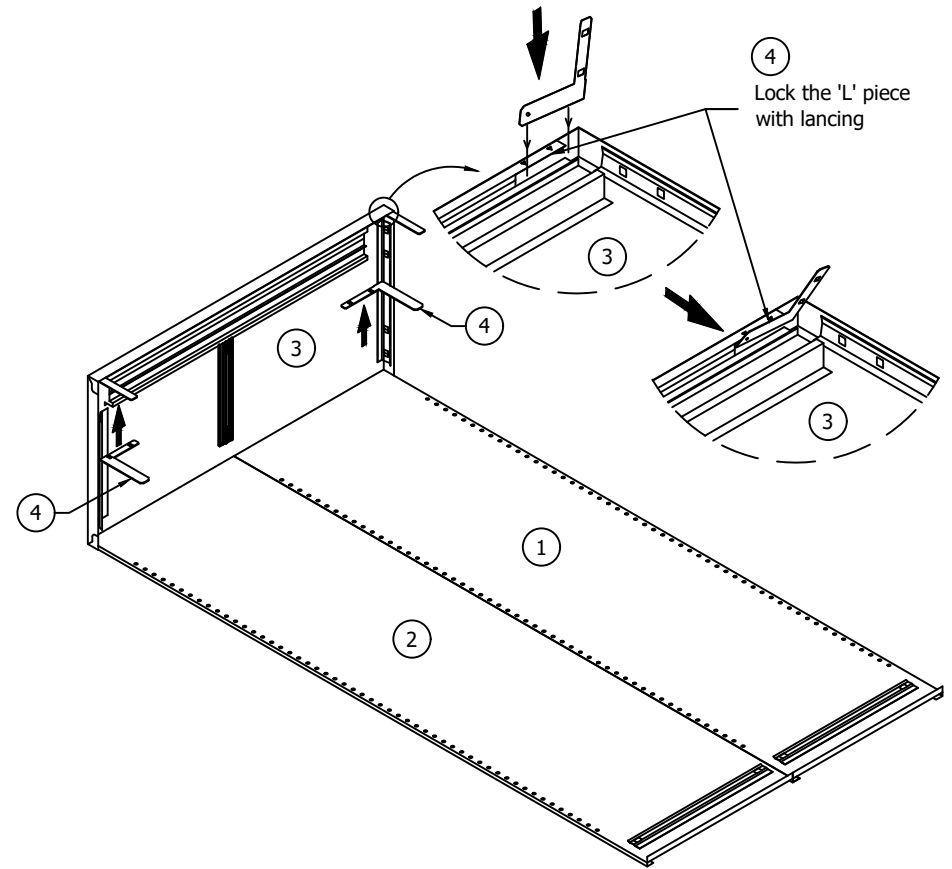

STEP: 4

Before the lancements are engaged with top retainers, ensure the side panel front & rear fold profiled edges are covered by panel.

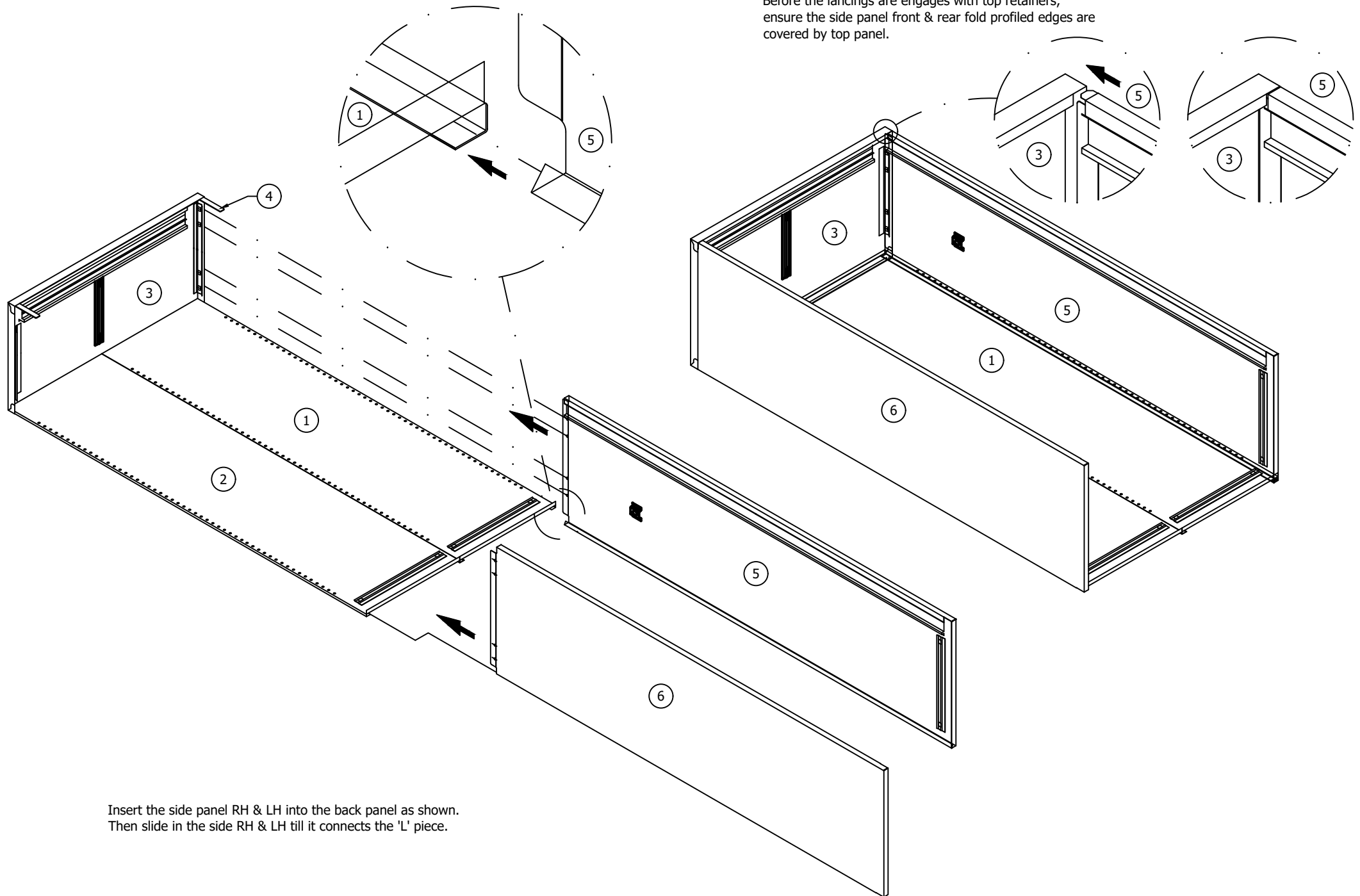

Insert the side panel RH & LH into the back panel as shown.  
Then slide in the side RH & LH till it connects the 'L' piece.

STEP: 5 KICK PLATE INSERTION

First locate the 'L' piece into the kick plate in cover and push through it. Then insert the kick plate into the side panel notching and make sure the kick plate is fully inserted as shown.

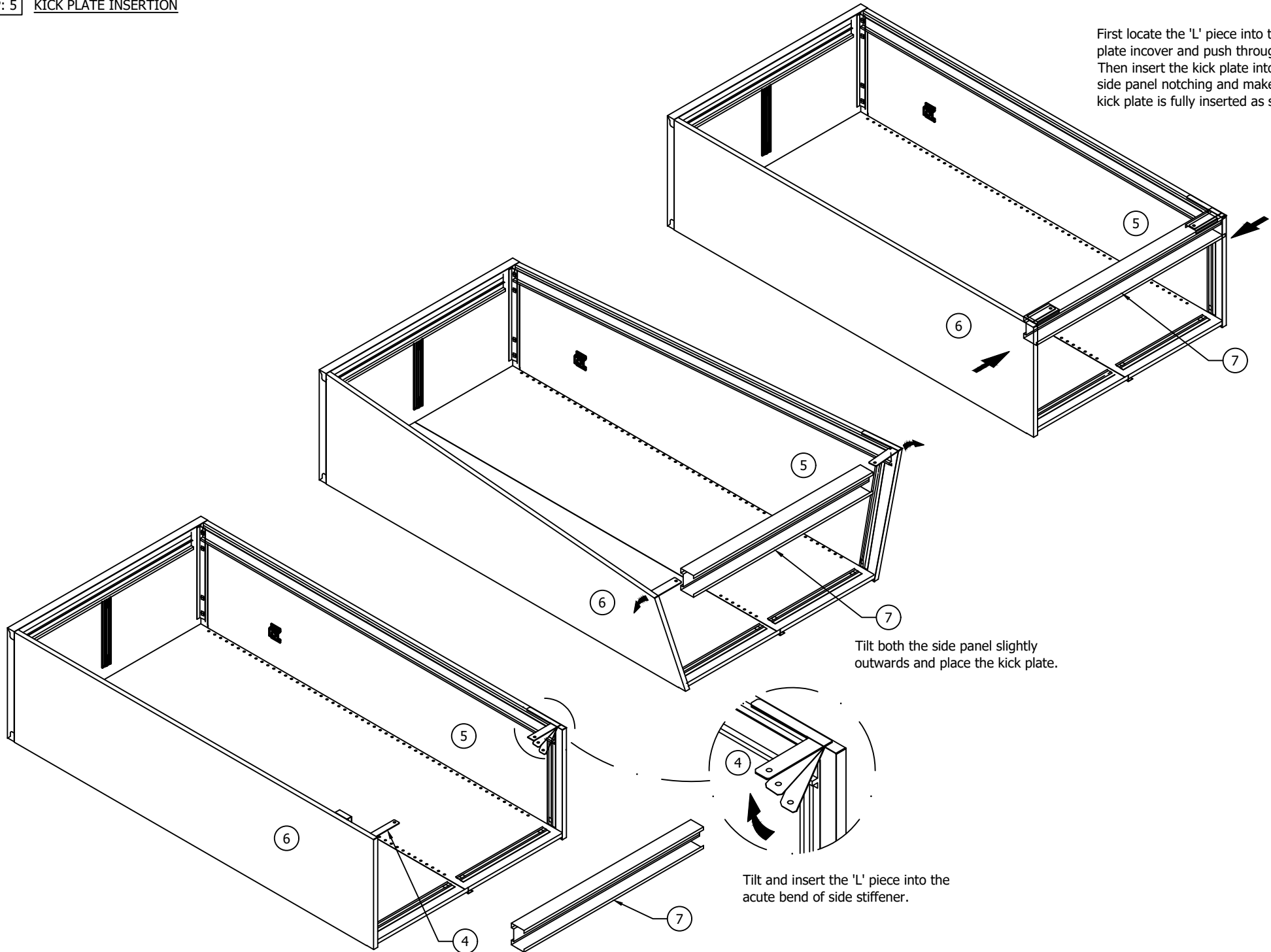

STEP: 6

BOTTOM CORNER PIECE FIXING

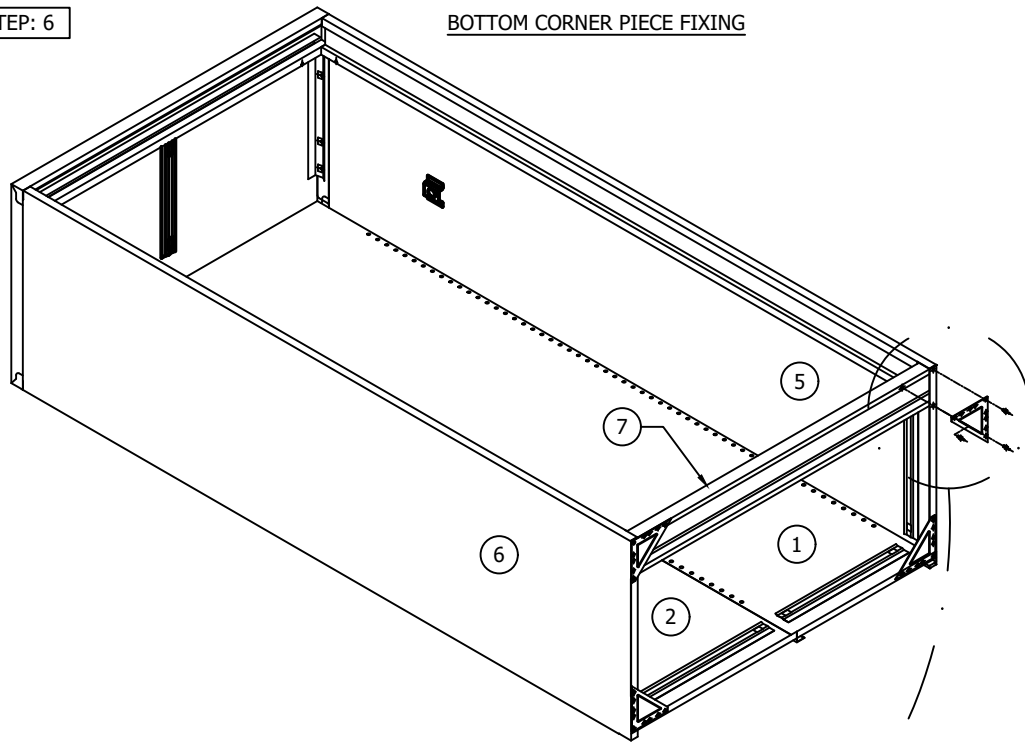

Pop-rivet four bottom corner pieces as shown in the figure.

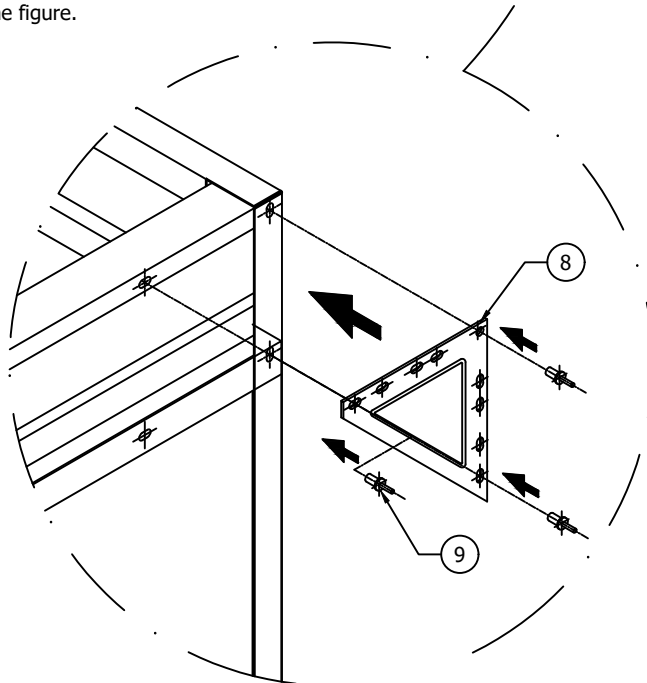

STEP: 7

BOTTOM PANEL FIXING

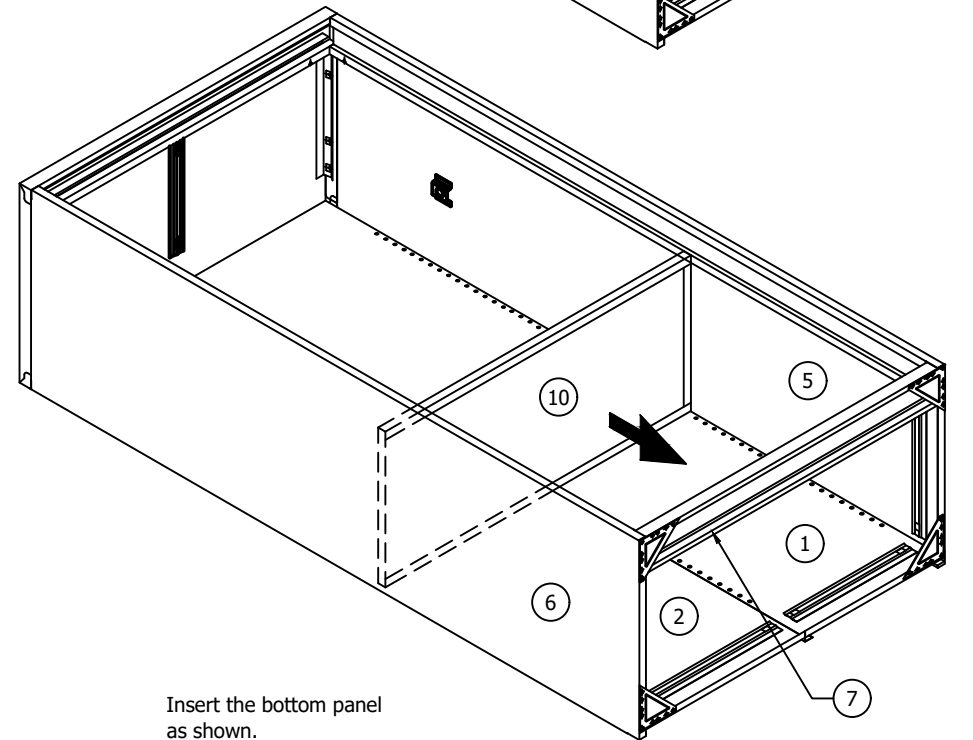
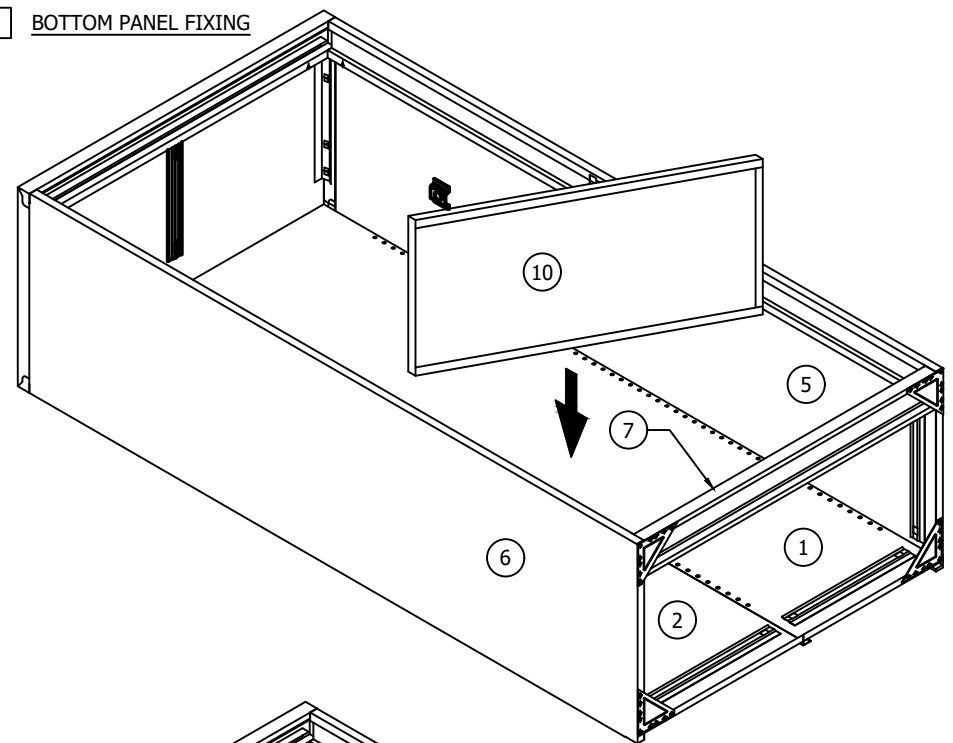

Insert the bottom panel as shown.

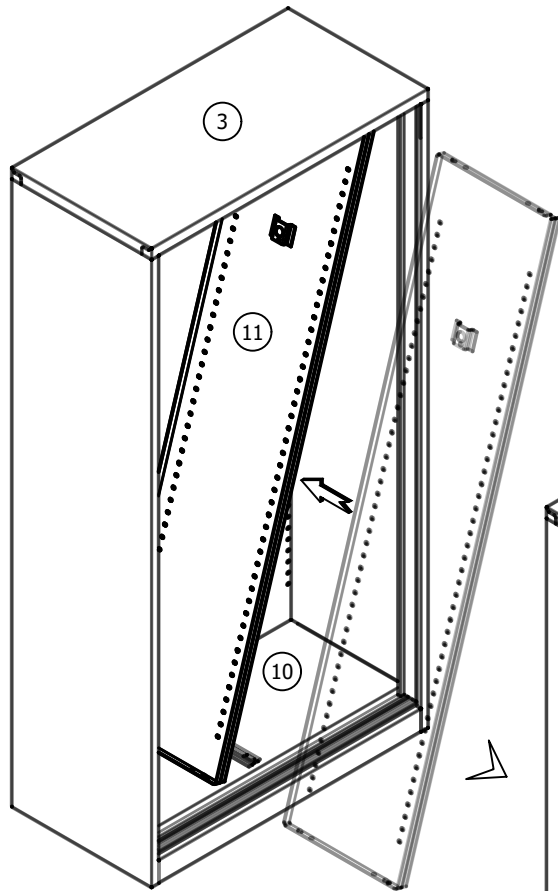

Place the hanger rod into the LH side hanger bracket and close the partition panel as shown.

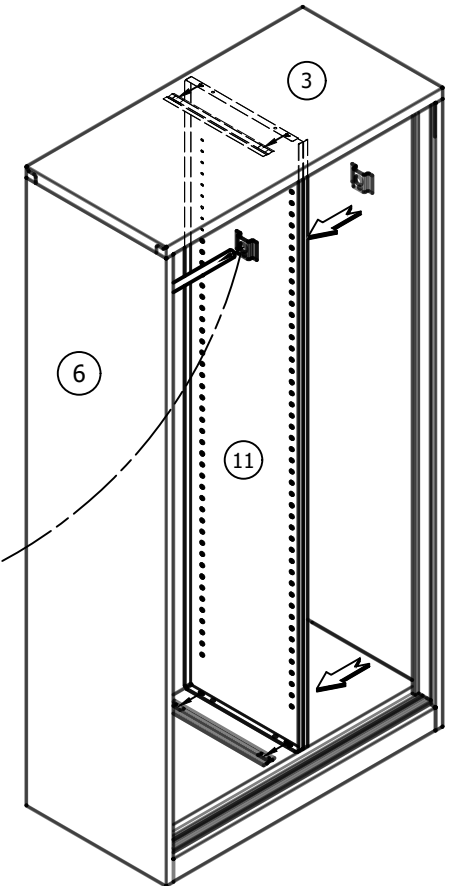
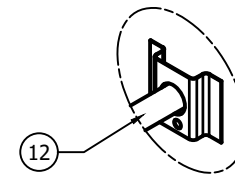
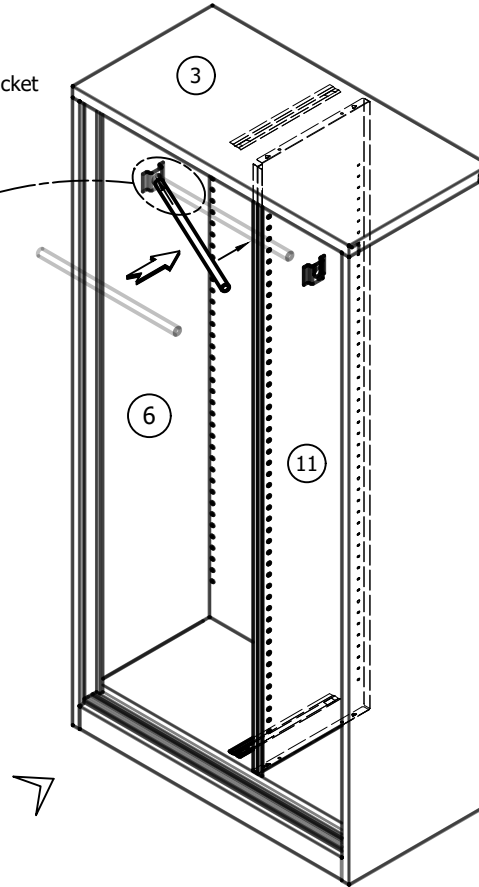
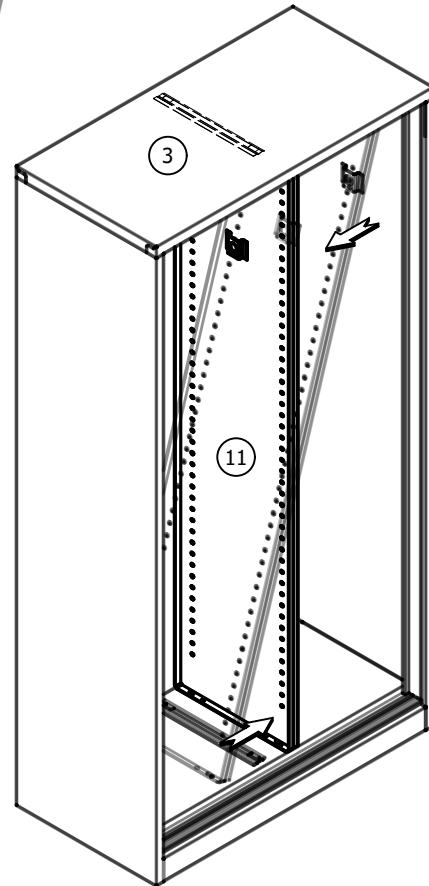
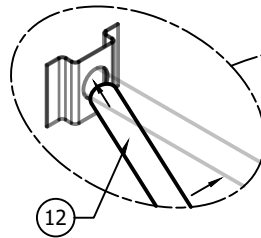

STEP: 9 HANGER ROD RIGHT SIDE FIXING

Place the hanger rod into the RH side hanger bracket.

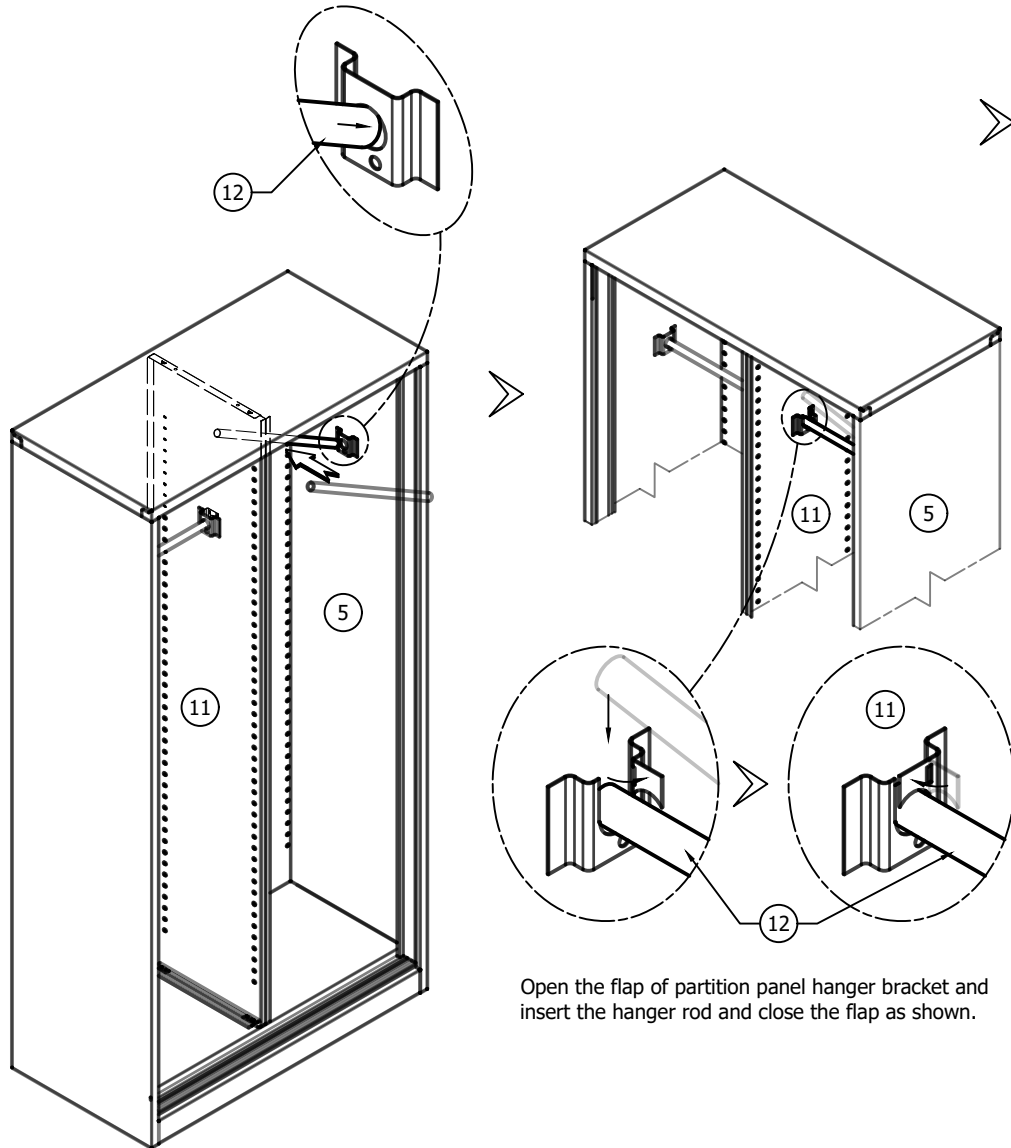

Open the flap of partition panel hanger bracket and insert the hanger rod and close the flap as shown.

STEP: 9 HALF SHELF PANEL FIXING

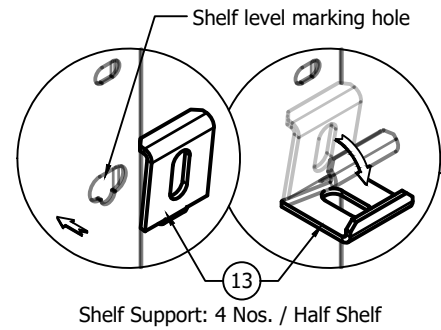

Fix the shelf support brackets in the level marking holes as shown.

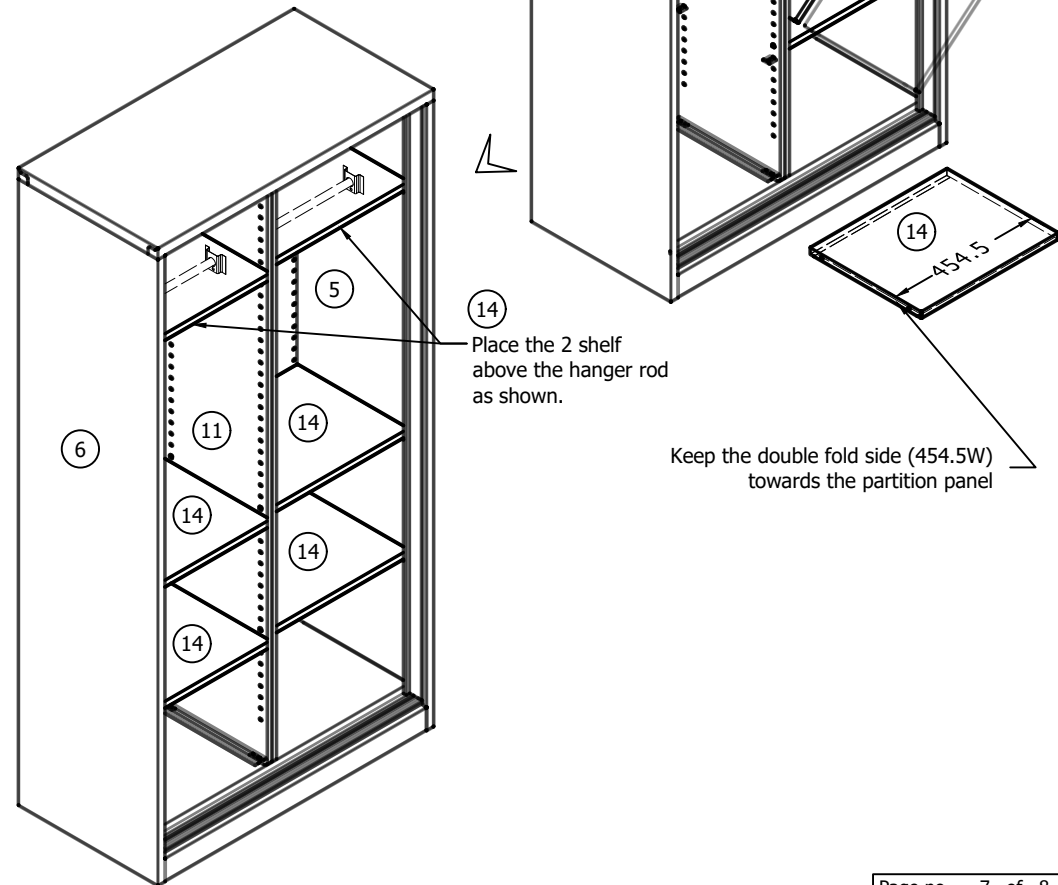

Place the 2 shelf above the hanger rod as shown.

Keep the double fold side (454.5W) towards the partition panel

STEP: 10 DOOR ASSEMBLY FIXING

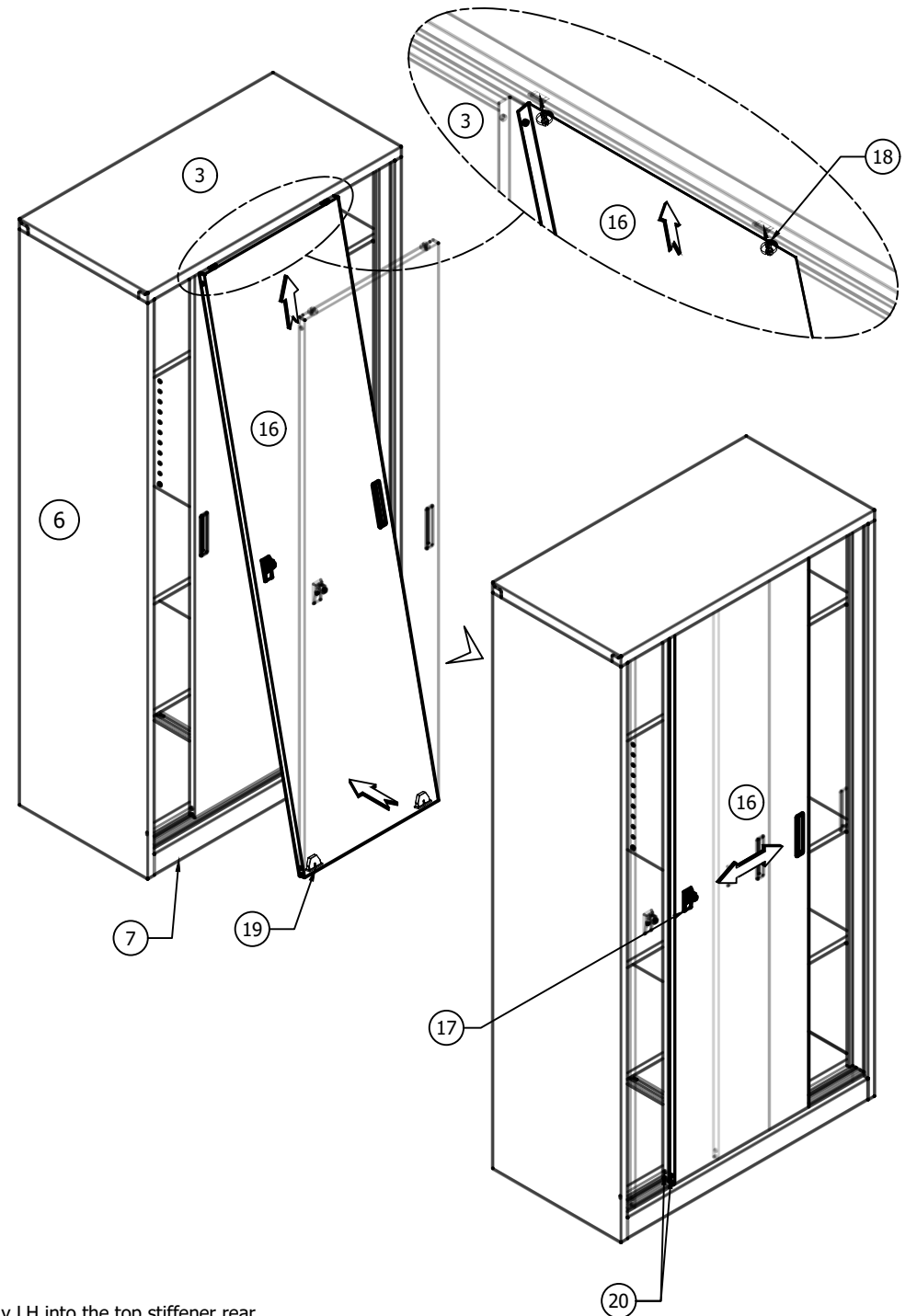
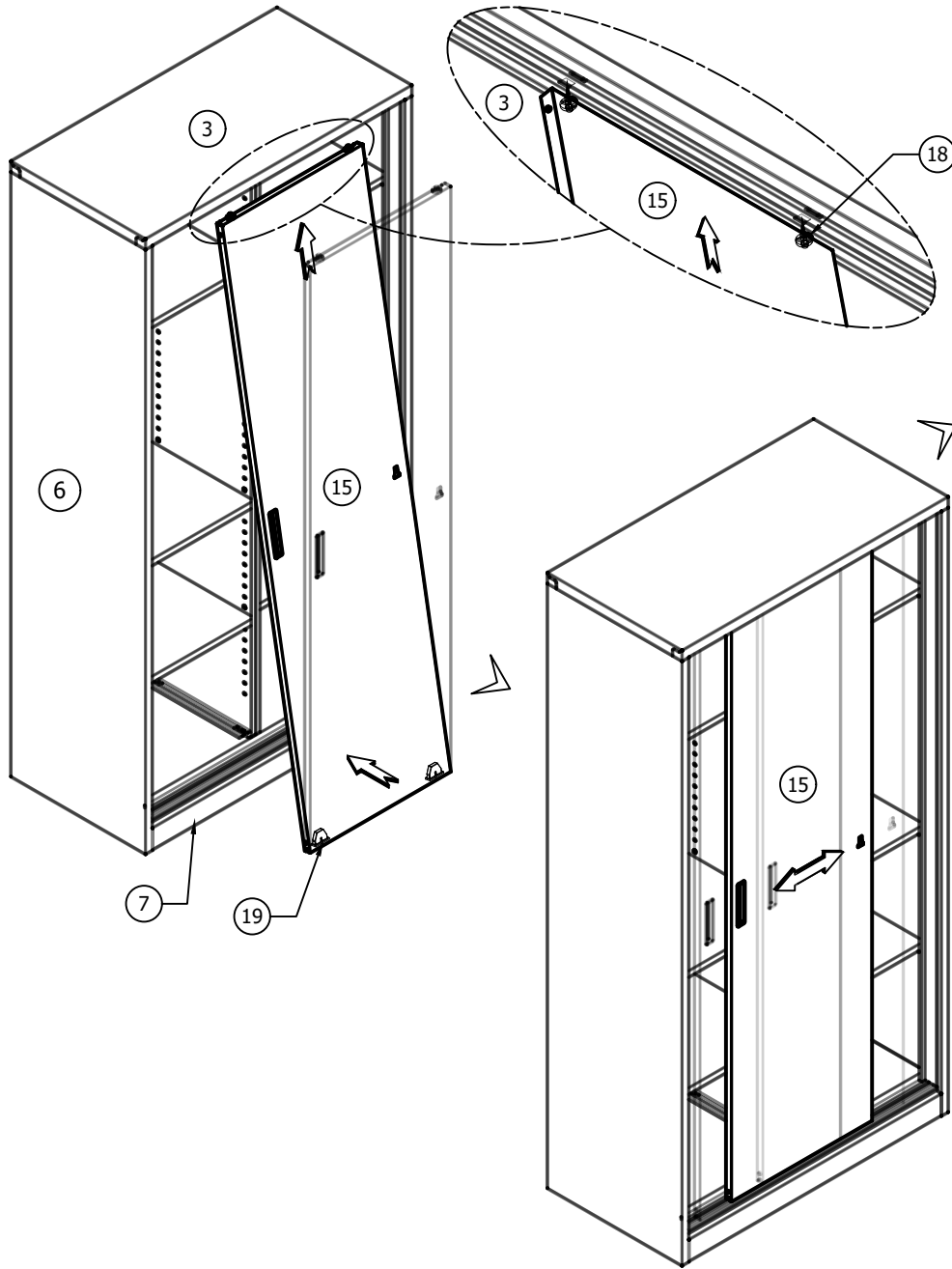

Locate the top rollers of door assembly LH into the top stiffener rear rectangle slots and guide the bottom rollers on kick plate rail.