

Assembly Instructions for Full Opening Door (FOD) Cupboard

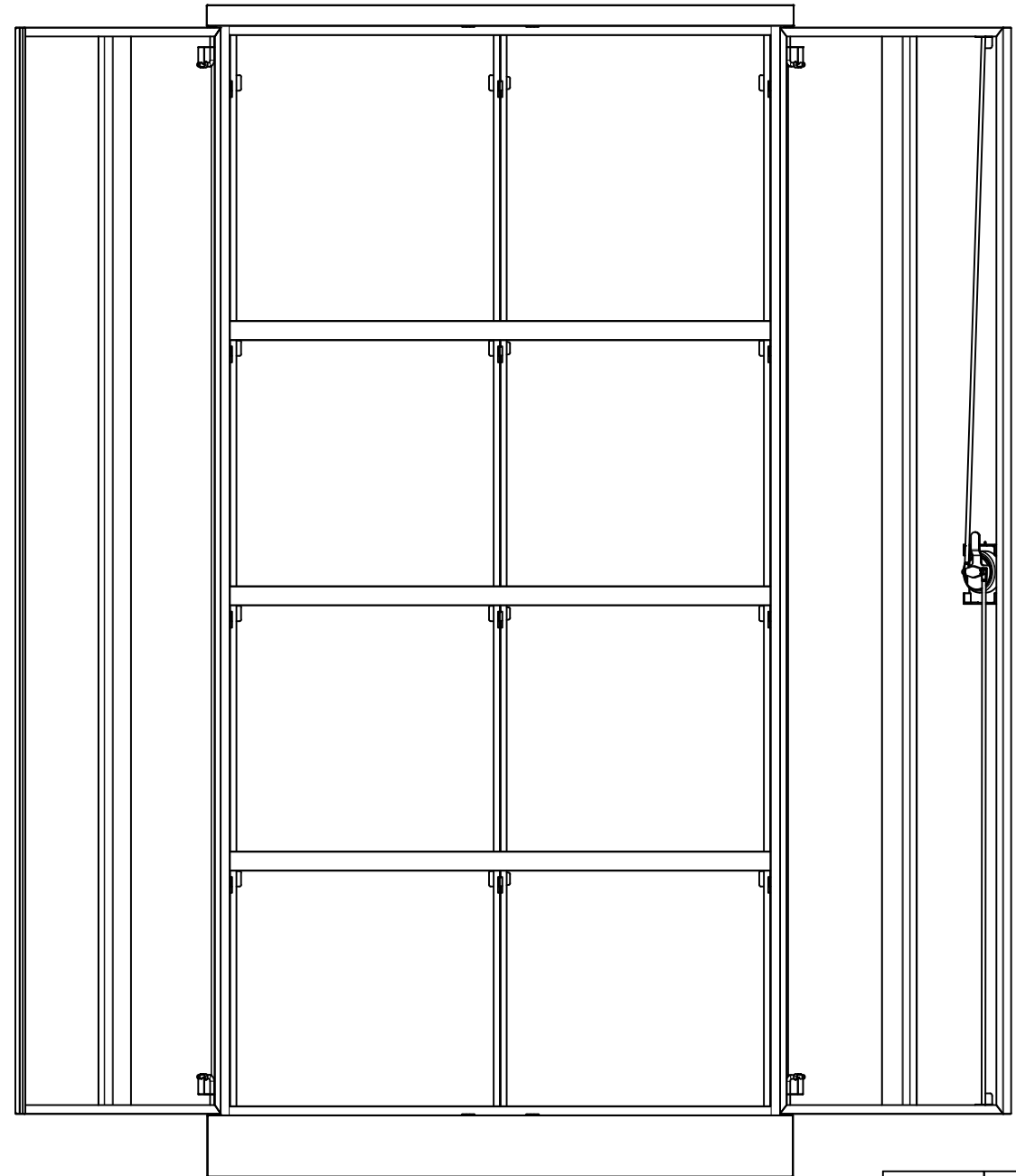

Parts for FOD Cupboard Assembly

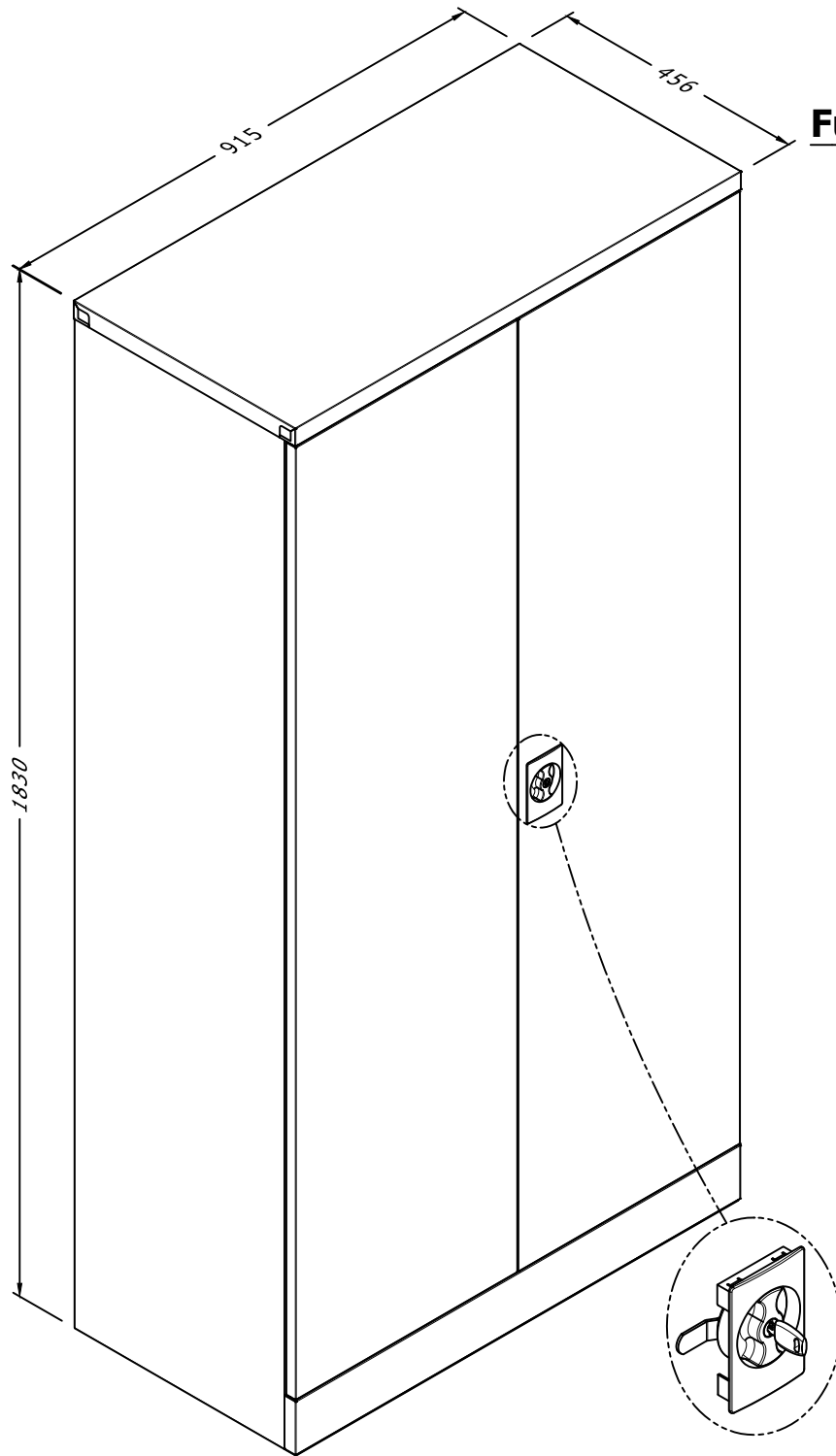
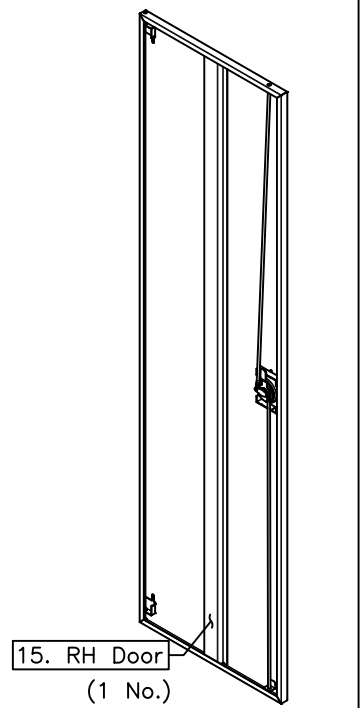
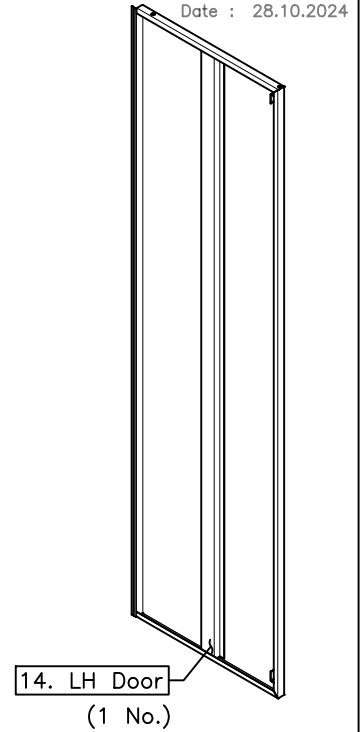
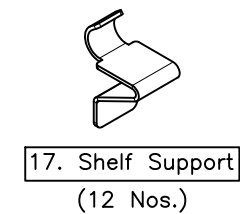
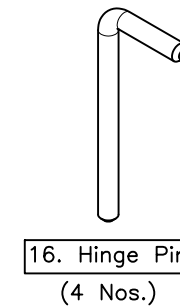
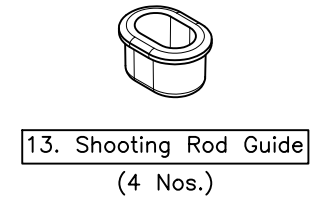
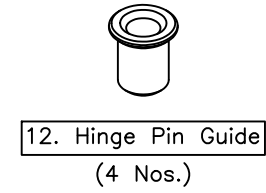
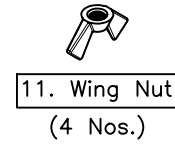
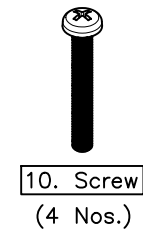
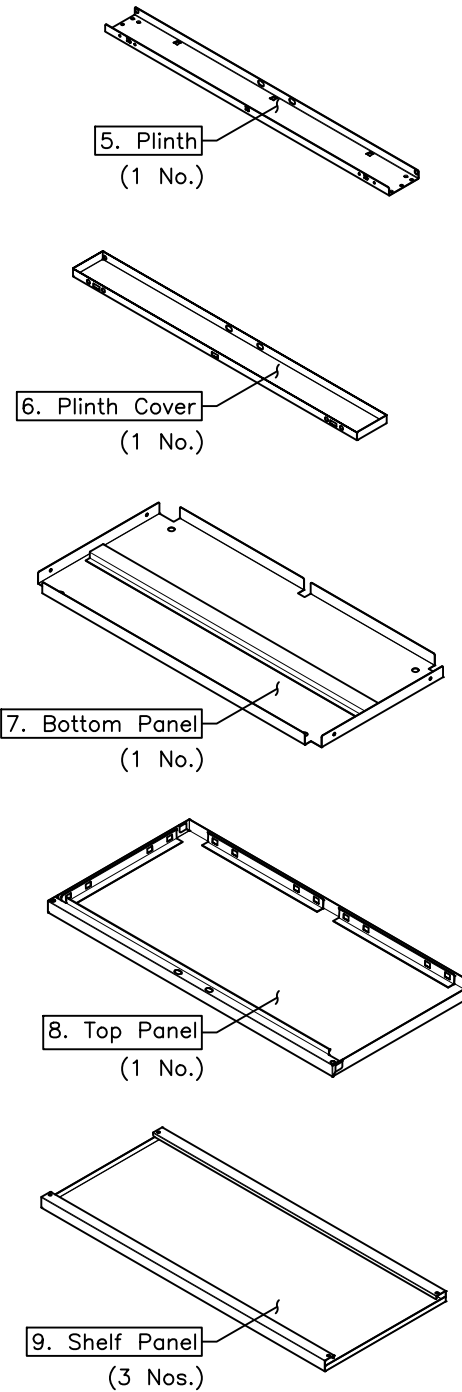
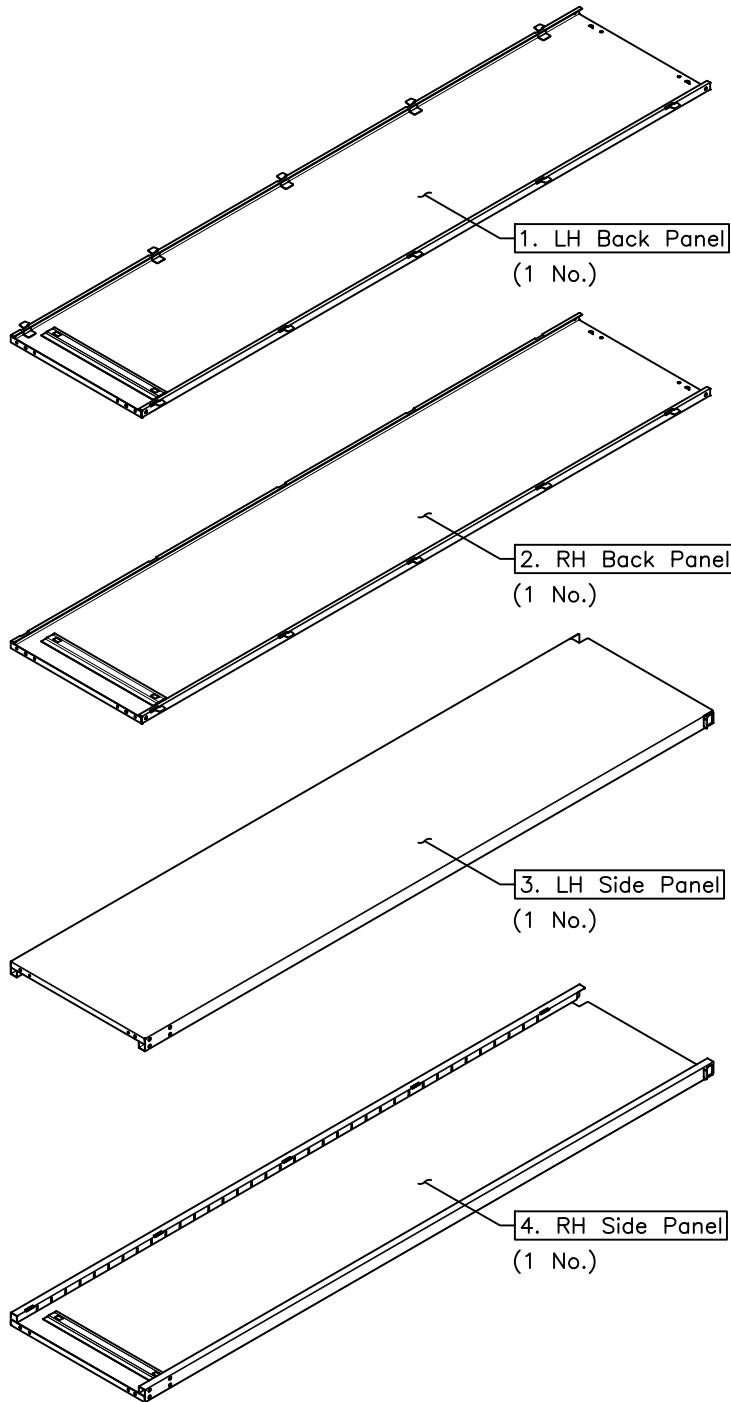

Step:1 Back Panel Joining

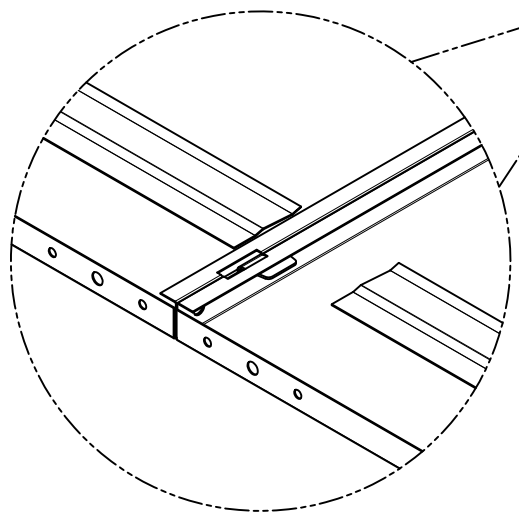
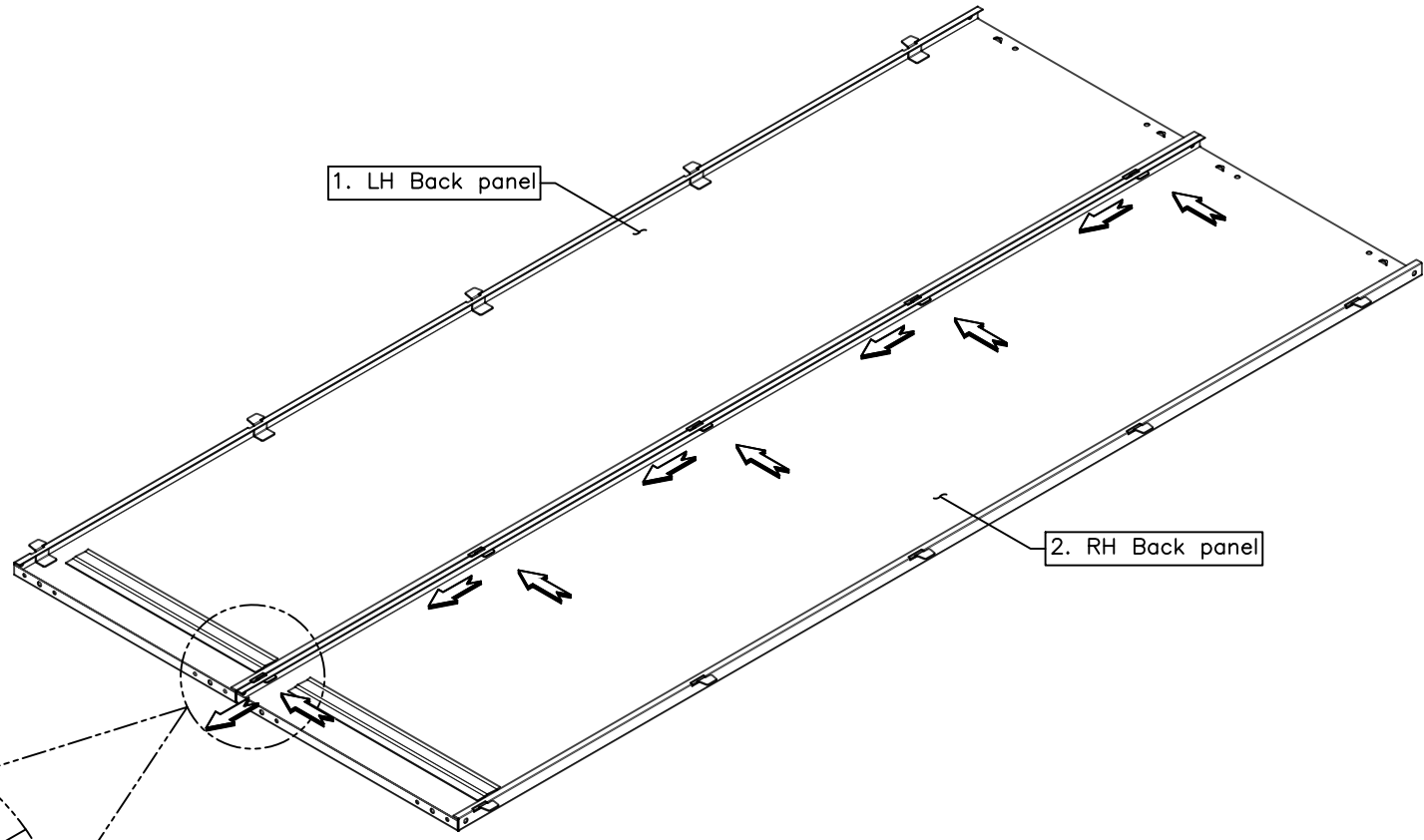
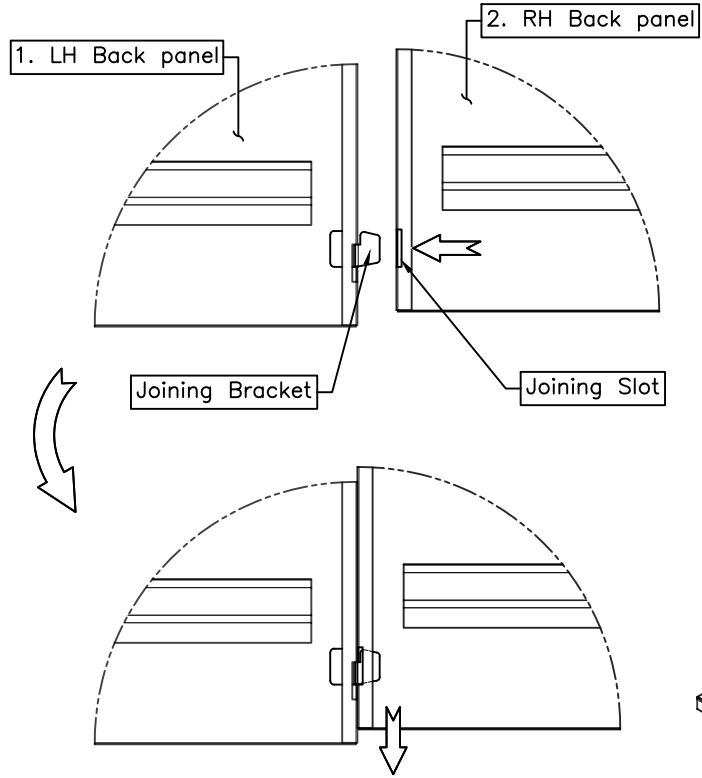

Align & hook the LH back panel joining brackets with RH back panel joining slots as shown.

Step:2.1 Side Panel Joining

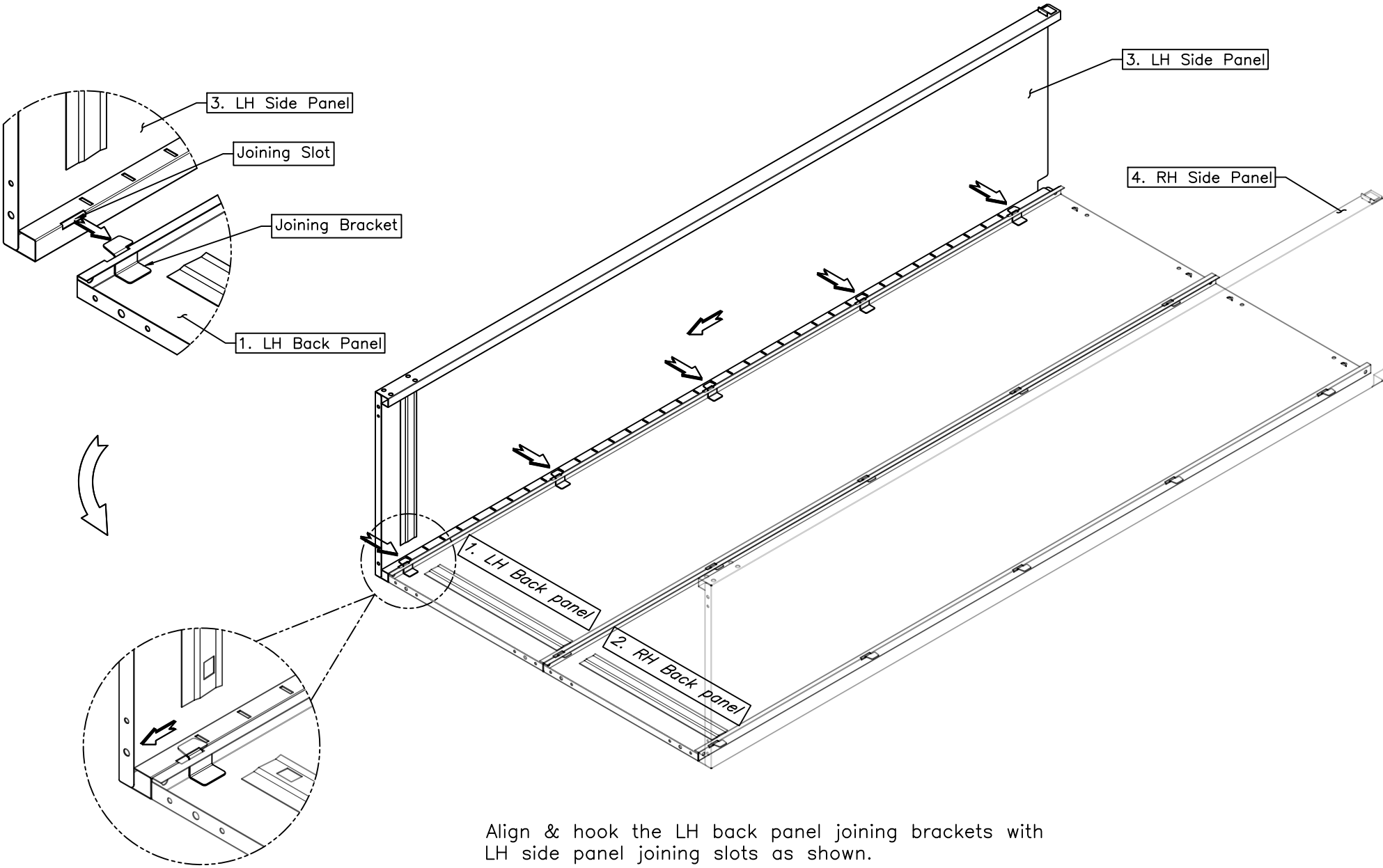

Align & hook the LH back panel joining brackets with LH side panel joining slots as shown.

Step:2.2 Plinth Fixing

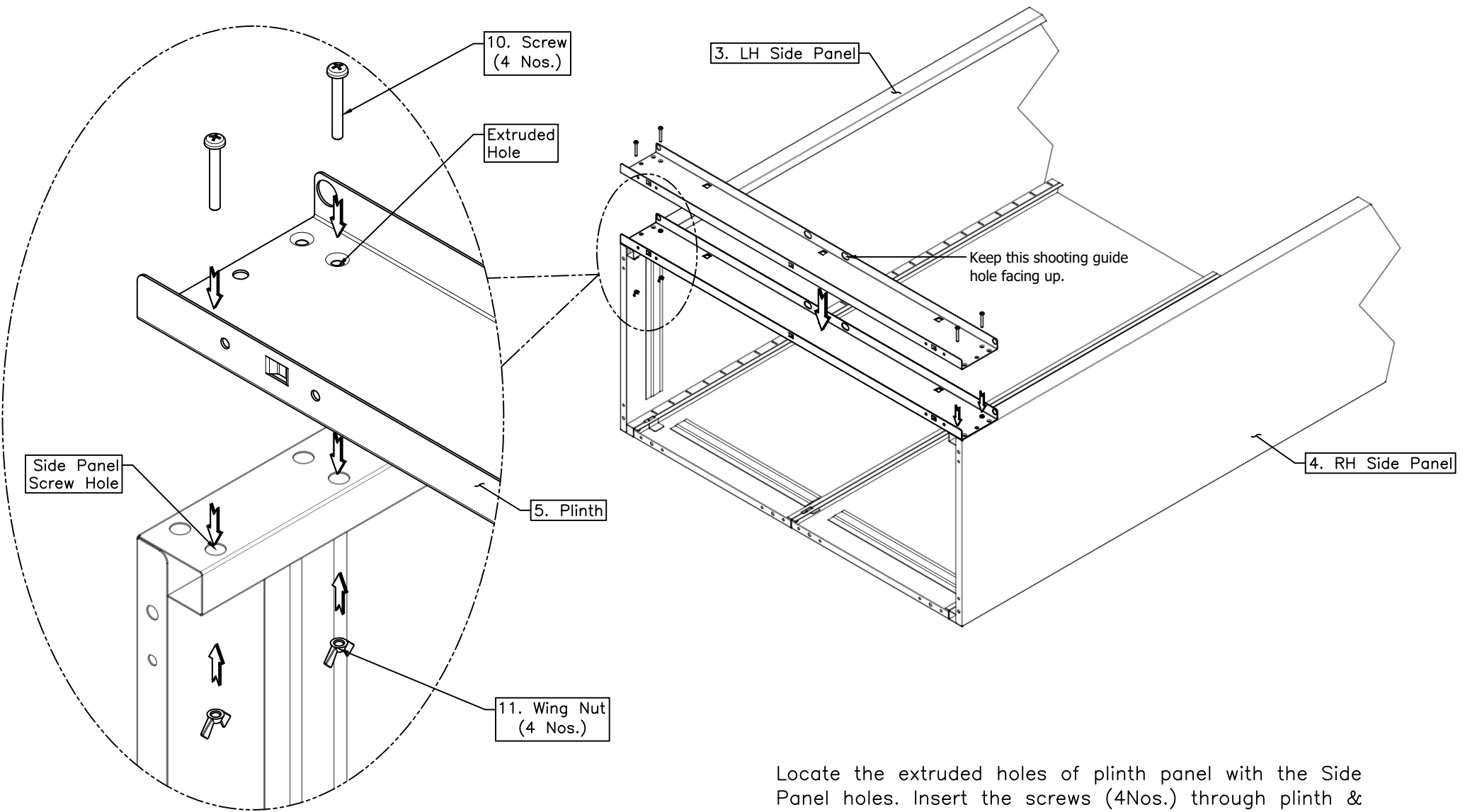

Locate the extruded holes of plinth panel with the Side Panel holes. Insert the screws (4Nos.) through plinth & side panel and fasten the wing nut as shown.

Step:3 Bottom Panel Fixing

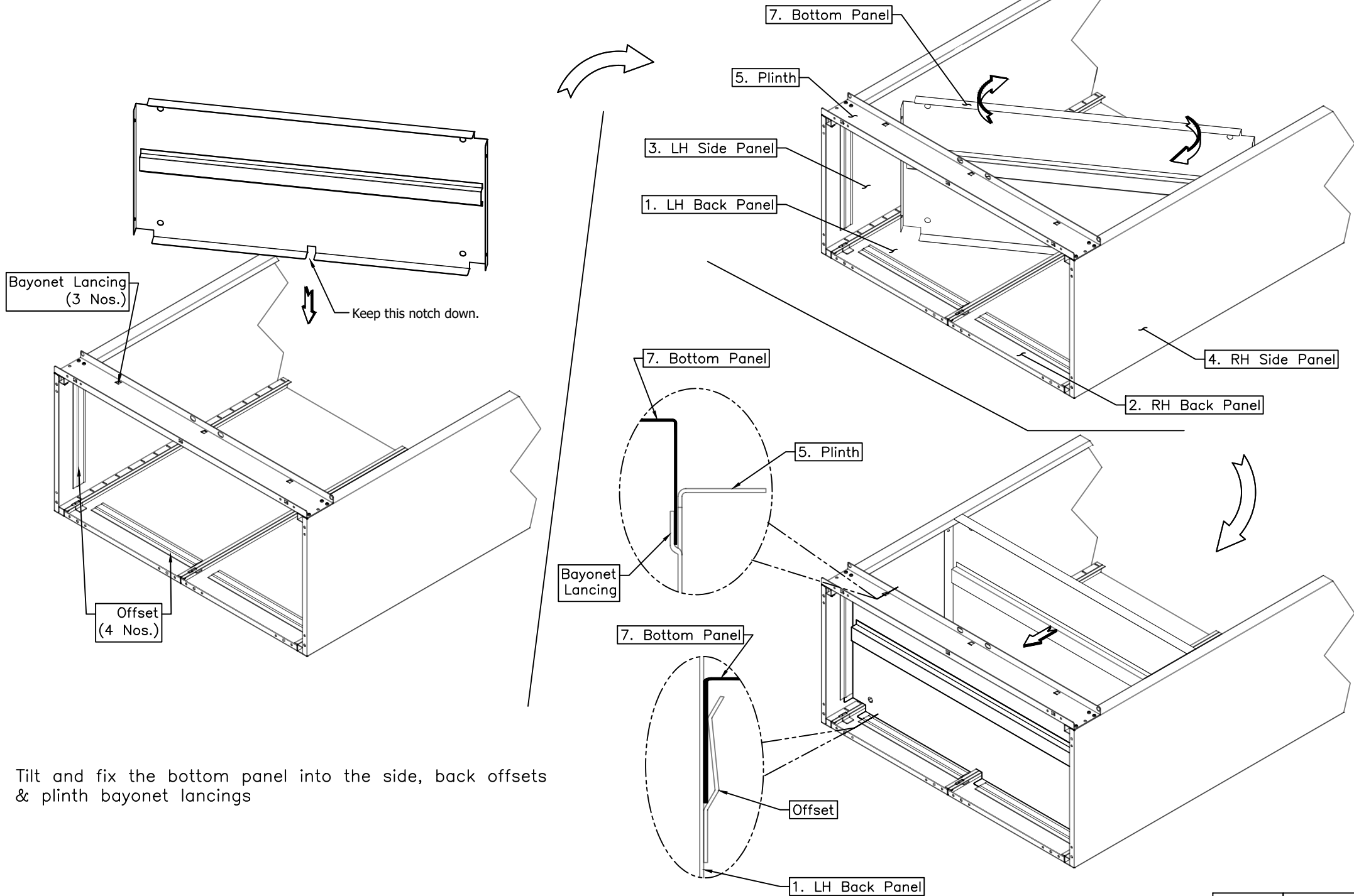

Step:4 Top Panel Fixing

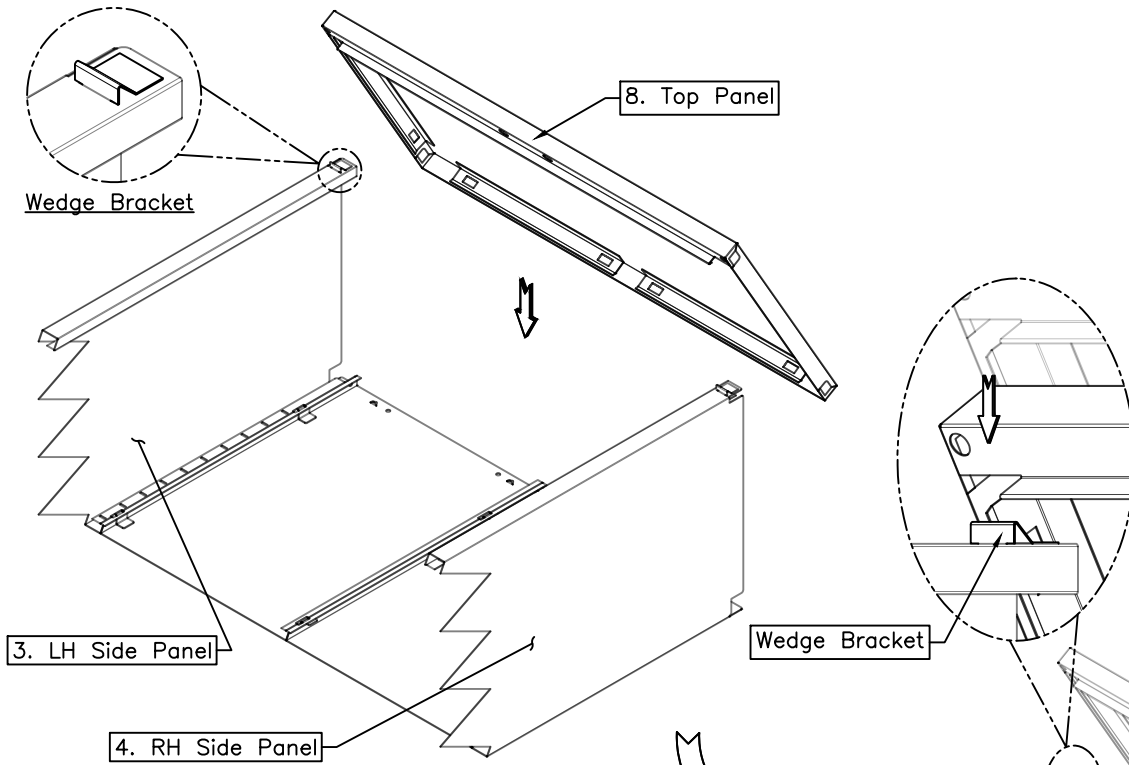

Hook the top panel front fold with side panel wedge brackets and close it with side & back. Make sure the side & back panel edges enter into the top angular and the lancings must click in with top angular rectangle window.

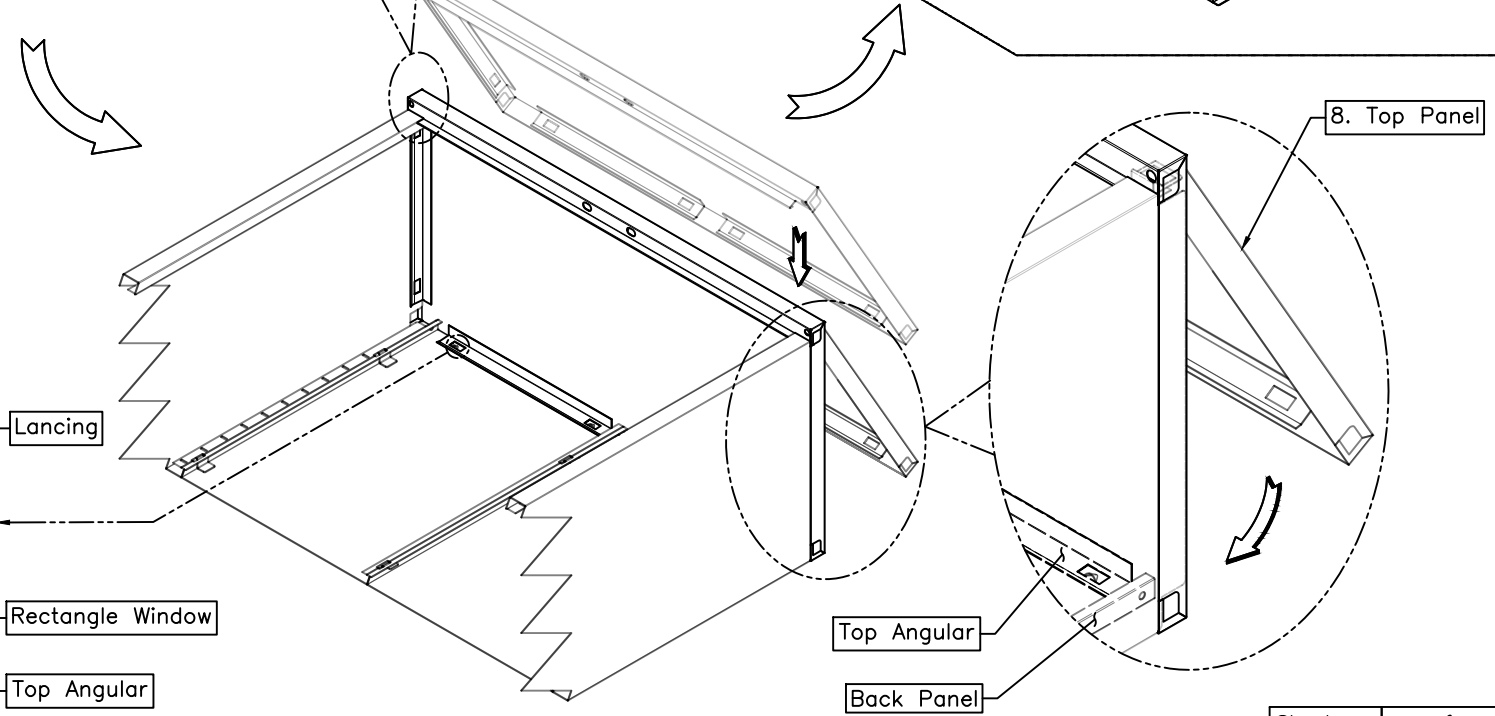
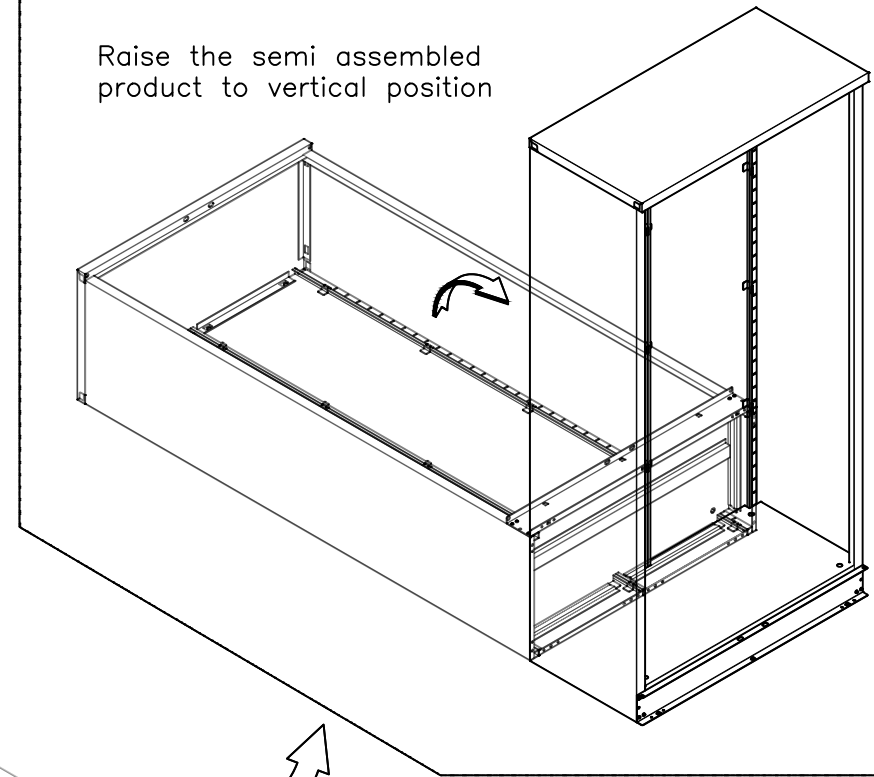
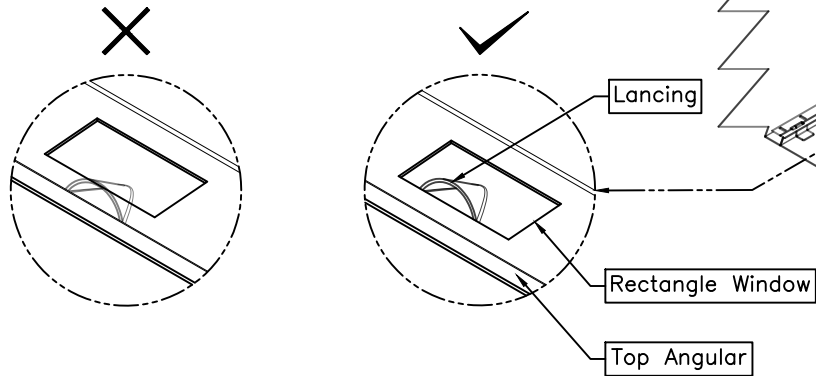

Step:5 Plinth Cover Fixing

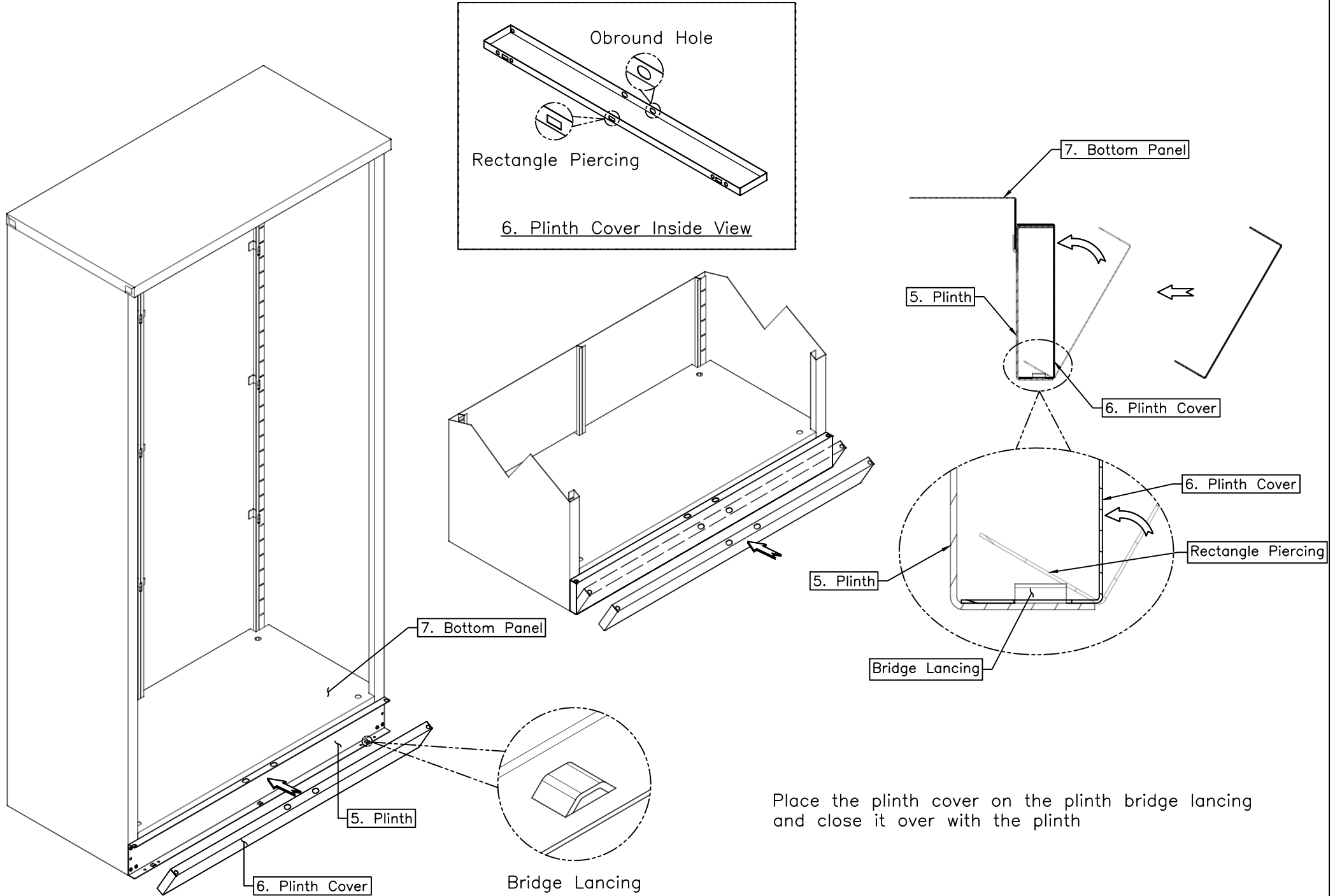

Step:6 Fixing of Hardware Components

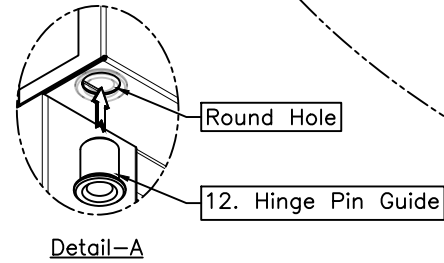
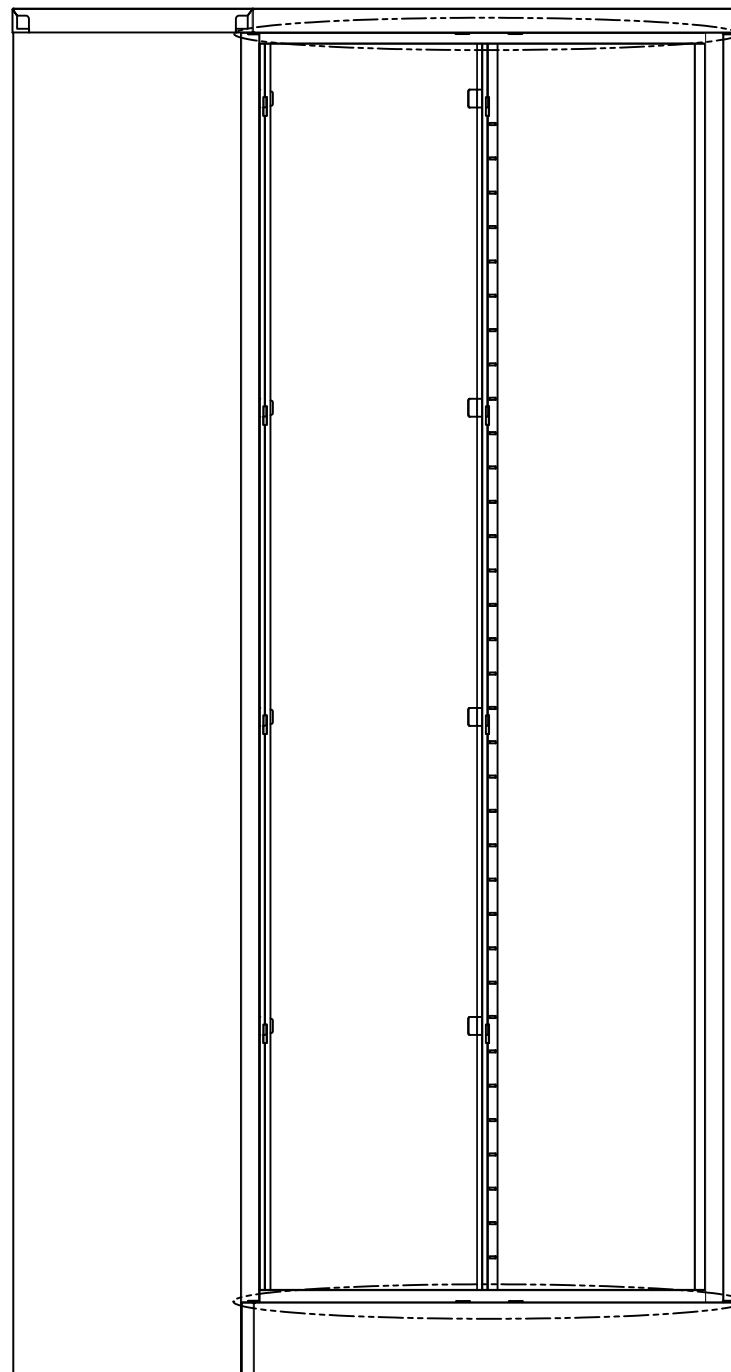

Round Hole

12. Hinge Pin Guide

Detail-A

Fix the hinge pin guide 2Nos. and shooting rod guide 2Nos. on the top panel.
Also fix the hinge pin guide 2Nos. and shooting rod guide 2Nos. on the plinth & plinth cover

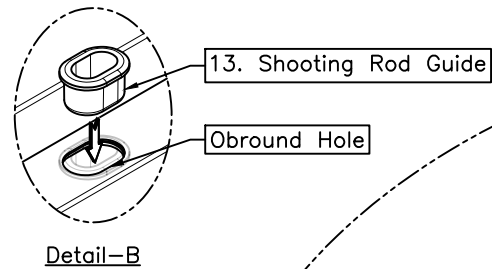

13. Shooting Rod Guide

Obround Hole

Detail-B

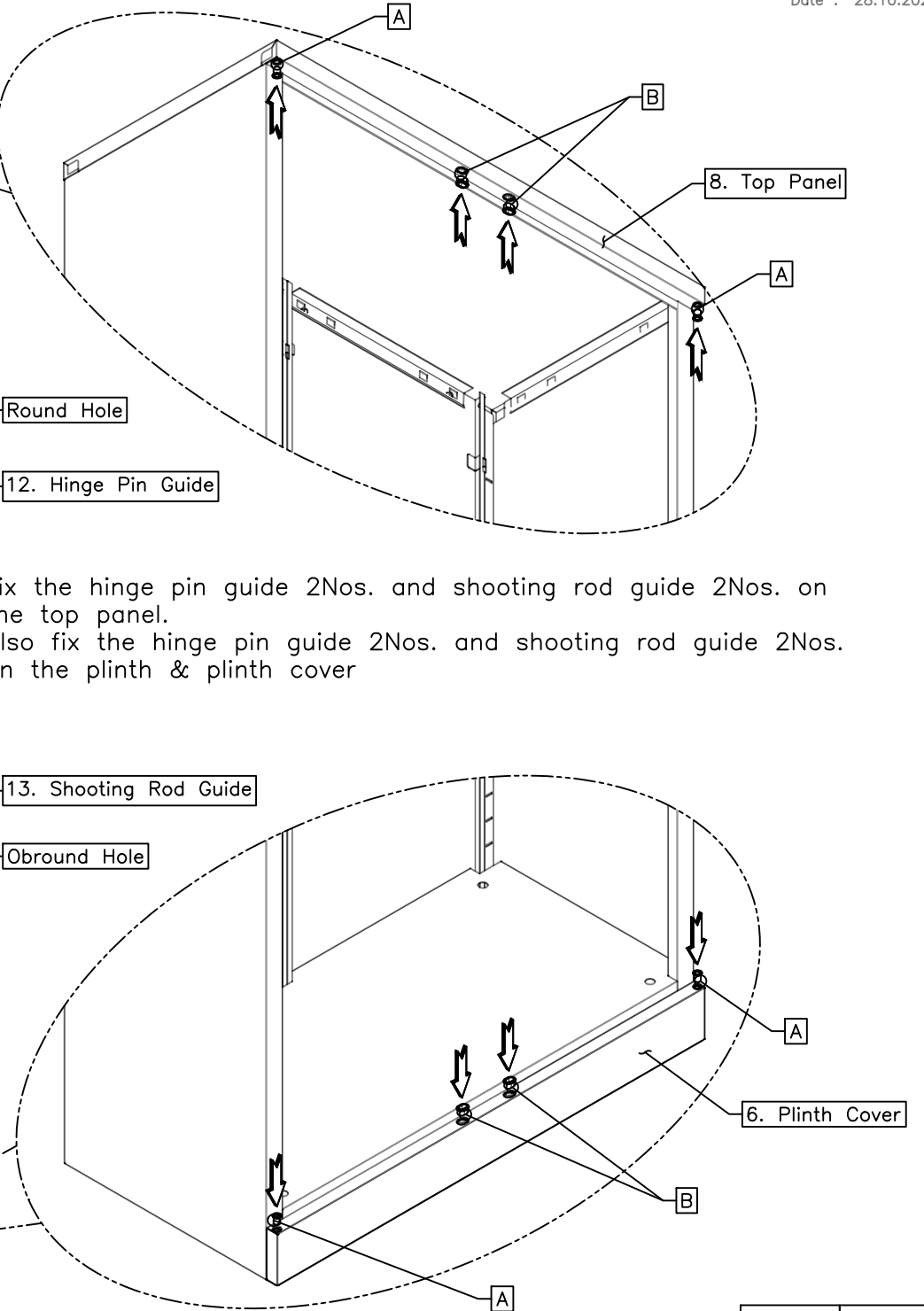

Step:7 Door Fixing

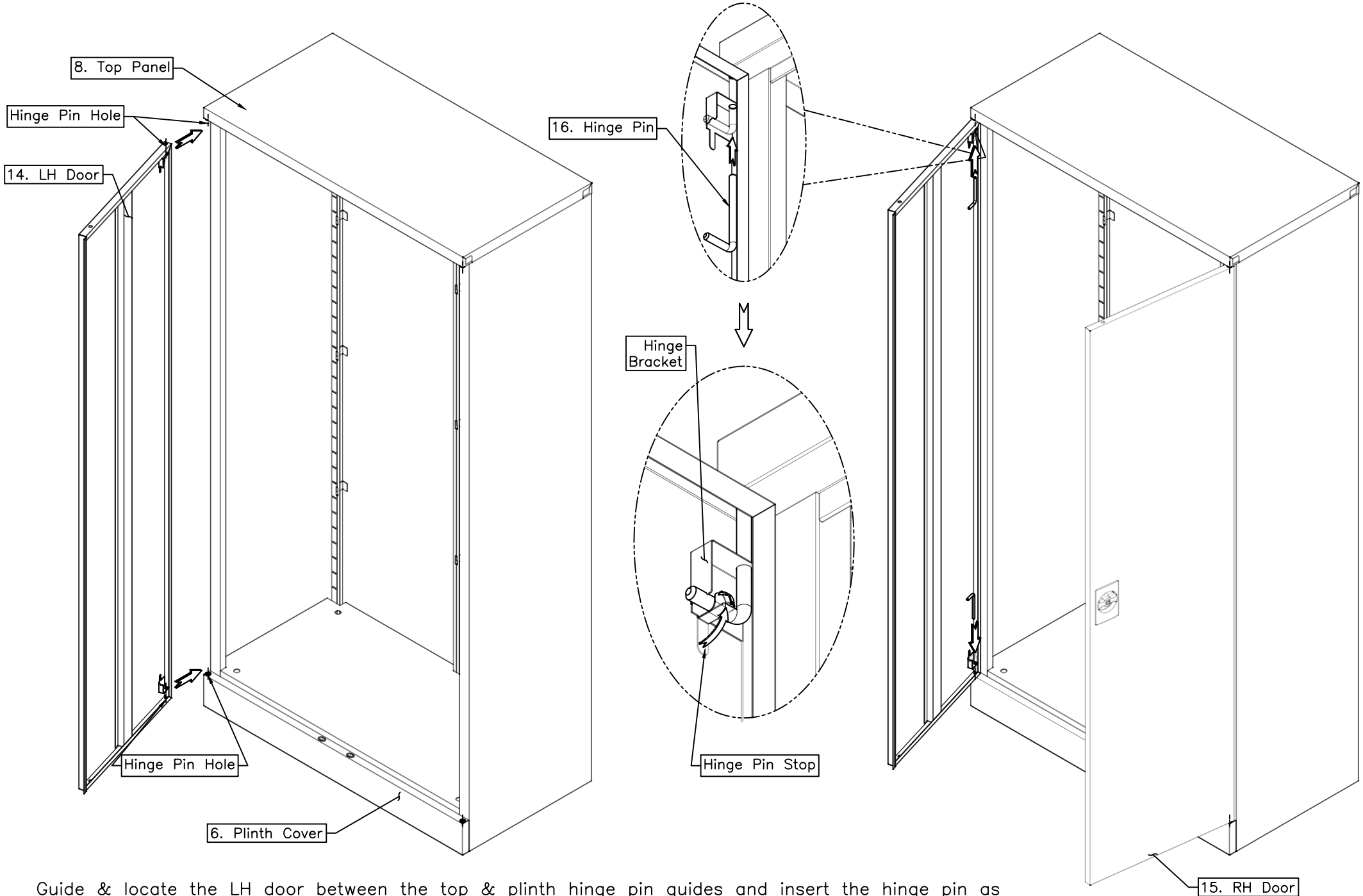

Guide & locate the LH door between the top & plinth hinge pin guides and insert the hinge pin as shown and fold the hinge bracket flap to hold the hinge pin. Repeat this for RH door

Step:8.1 Shelf Support Mounting

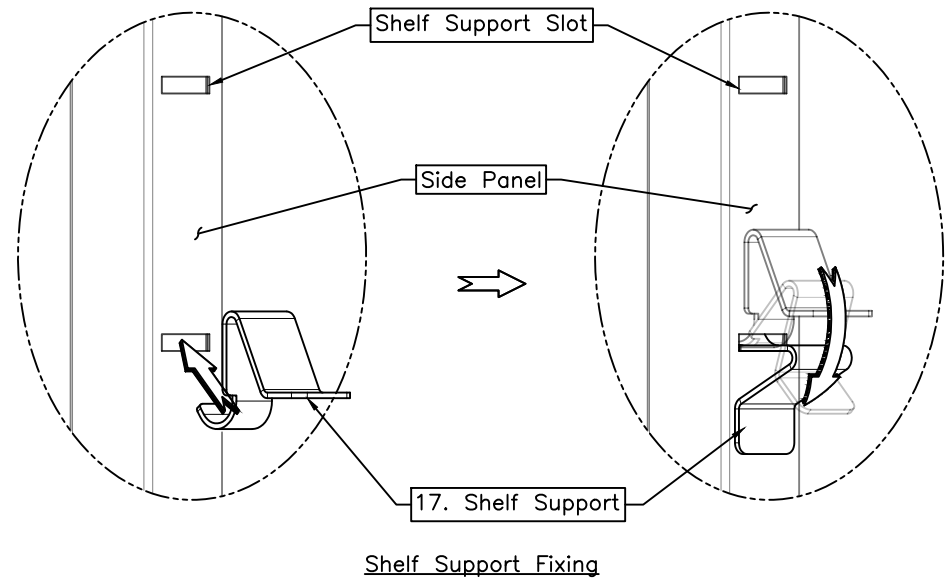
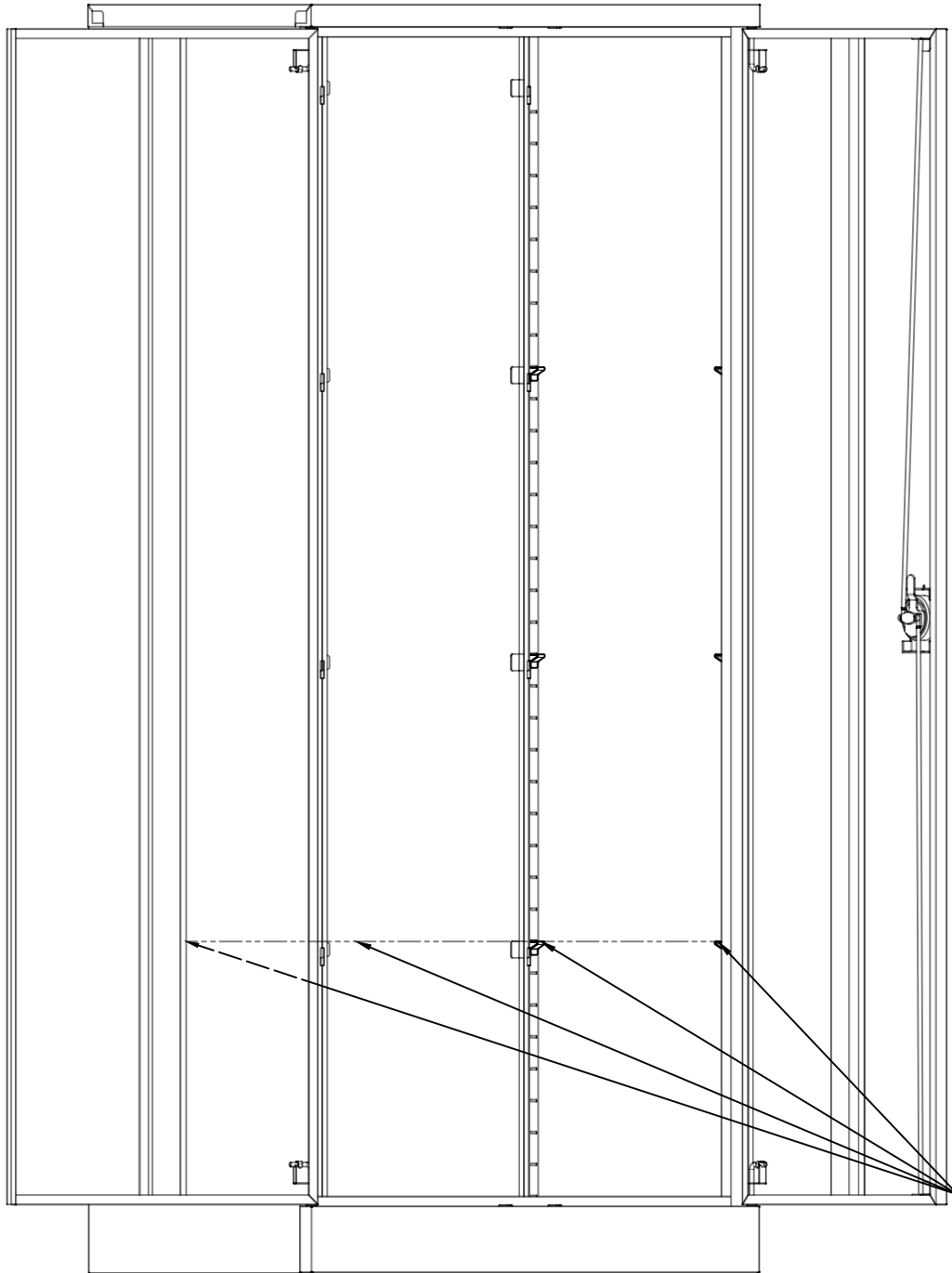

Fix the shelf support brackets (4Nos) in line at the desired place and level as shown.

17. Shelf Support
(4 Nos./Shelf)

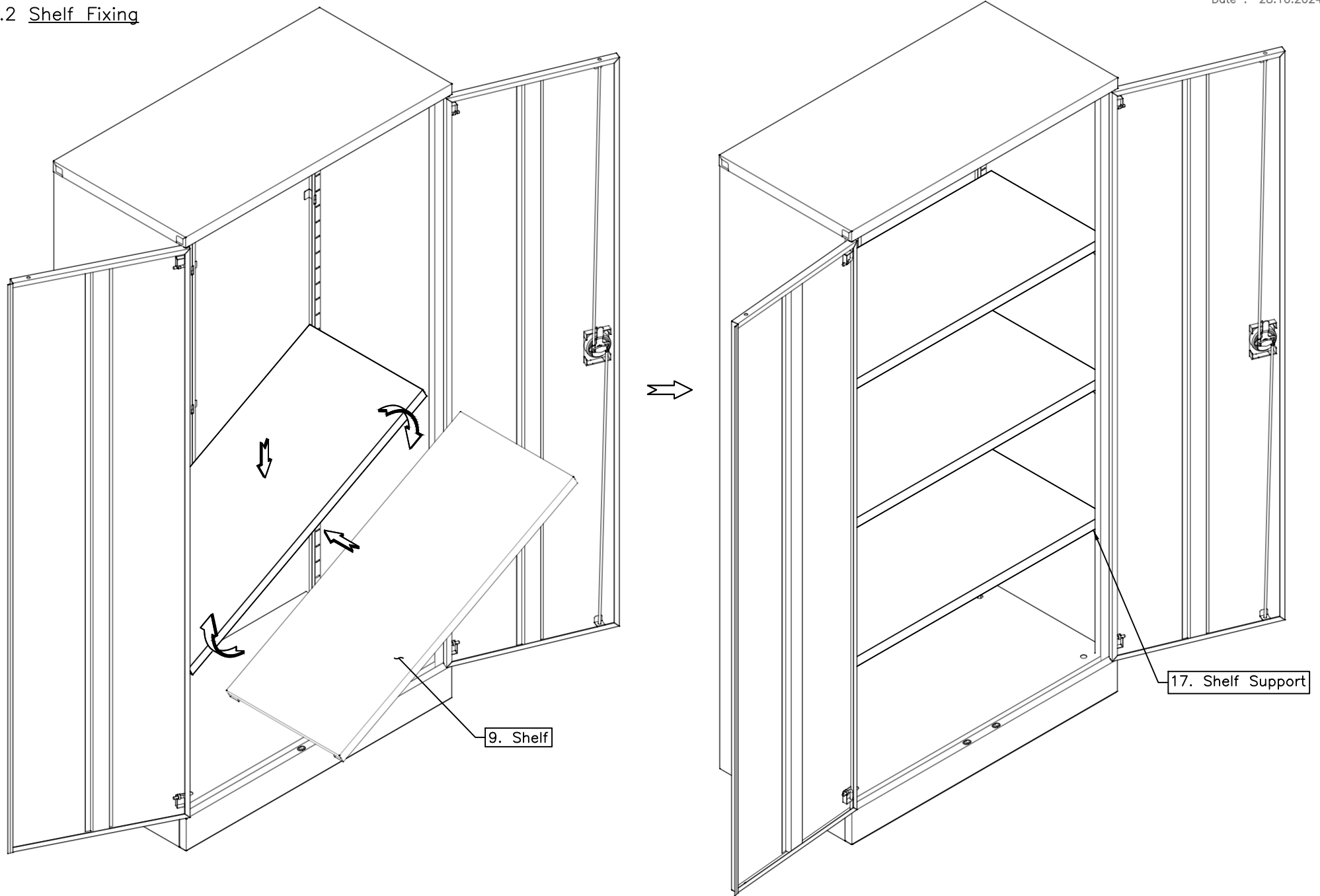

Insert the shelf panel in tilted position and place it on the shelf supports as shown.