

# ASSEMBLY INSTRUCTION FOR SLIDING DOOR UNIT

- \* PLEASE STUDY THE ASSEMBLY INSTRUCTIONS CAREFULLY & FAMILIARISE YOURSELF WITH THE PARTS BEFORE ASSEMBLY
- \* TOOLS REQUIRED : SCREW DRIVER, POP RIVET MACHINE & SOFT HAMMER.
- \* ENSURE THAT ALL THE ITEMS LISTED IN PART LIST ARE PRESENT BEFORE ASSEMBLY.

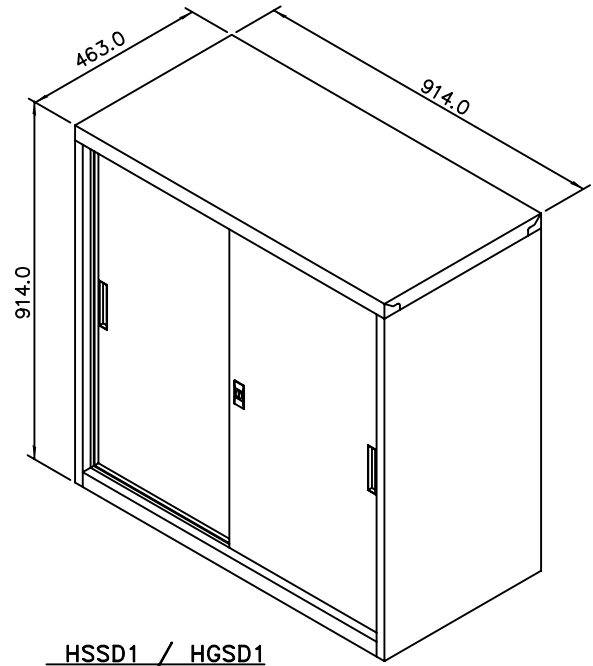
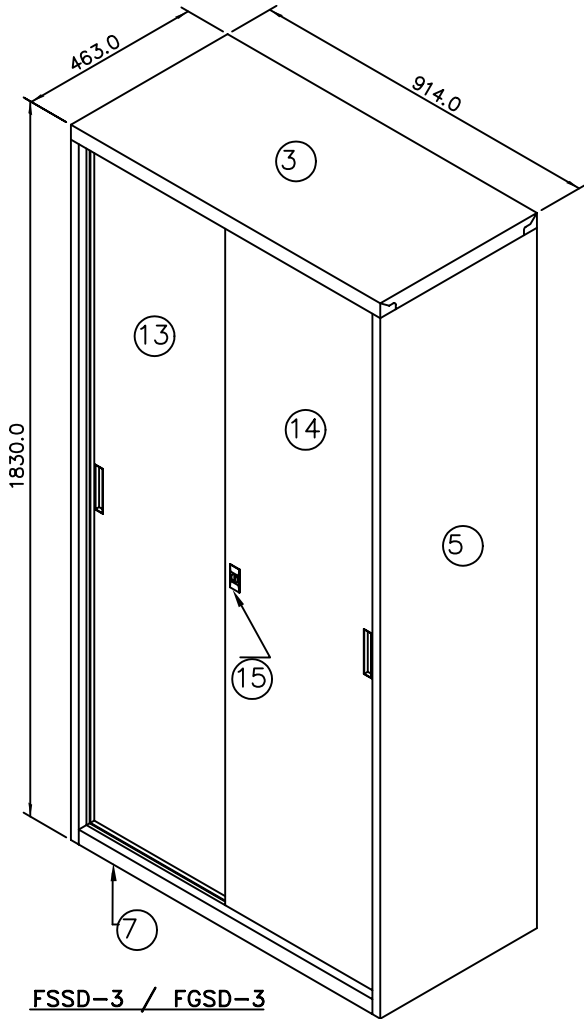

PART. NO.	DESCRIPTION	QTY.	
		FSSD3	HSSD1
1	BACK RH	1	1
2	BACK LH	1	1
3	TOP PANEL	1	1
4	'L' PIECE	4	4
5	SIDE PANEL RH	1	1
6	SIDE PANEL LH	1	1
7	KICK PLATE	1	1
8	BOTTOM CORNER PIECE	4	4
9	POP RIVET	12	12
10	BOTTOM PANEL	1	1
11	SHELF SUPPORT	15	5
12	SHELF	3	1
13	DOOR ASSEMBLY L.H.	1	1
14	DOOR ASSEMBLY R.H.	1	1
15	SDU LOCK	1	1
16	TOP ROLLER	4	4
17	BOTTOM ROLLER	4	4

ACCESSORIES :

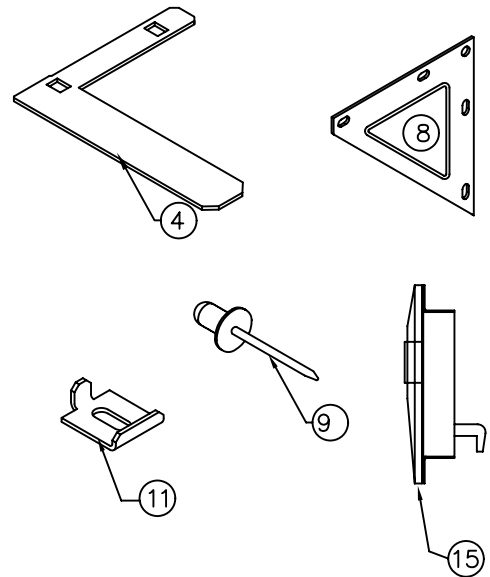

STEP : 1

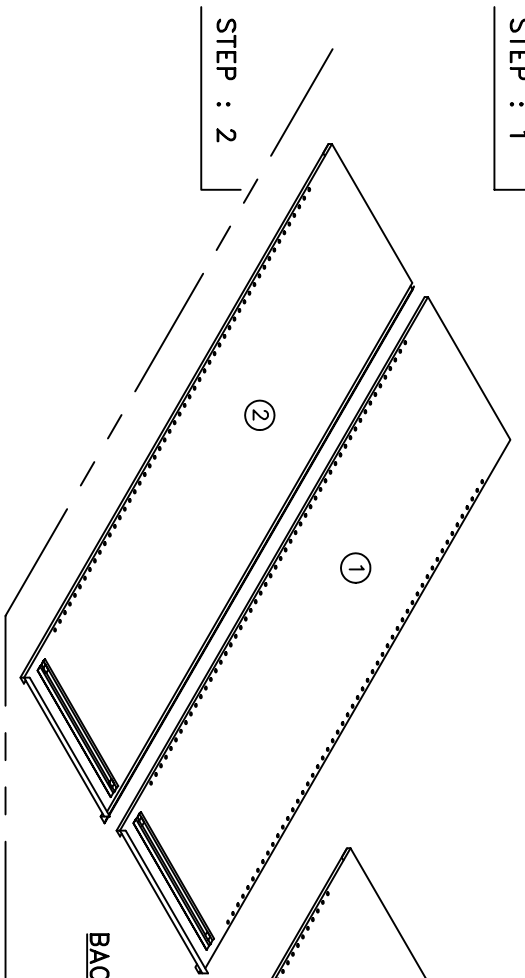

BACK ASSEMBLY

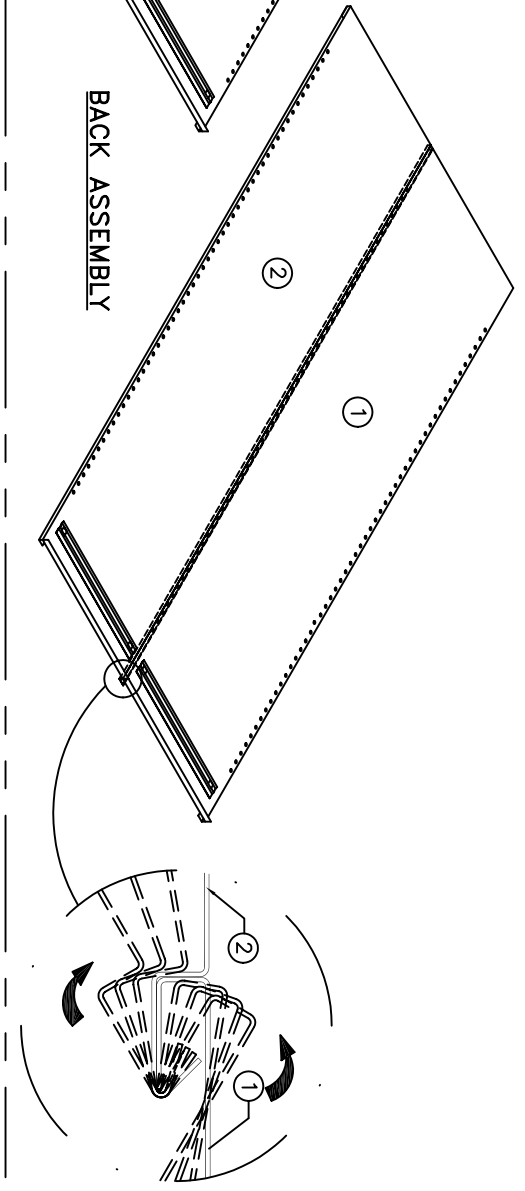

STEP : 2

STEP : 3

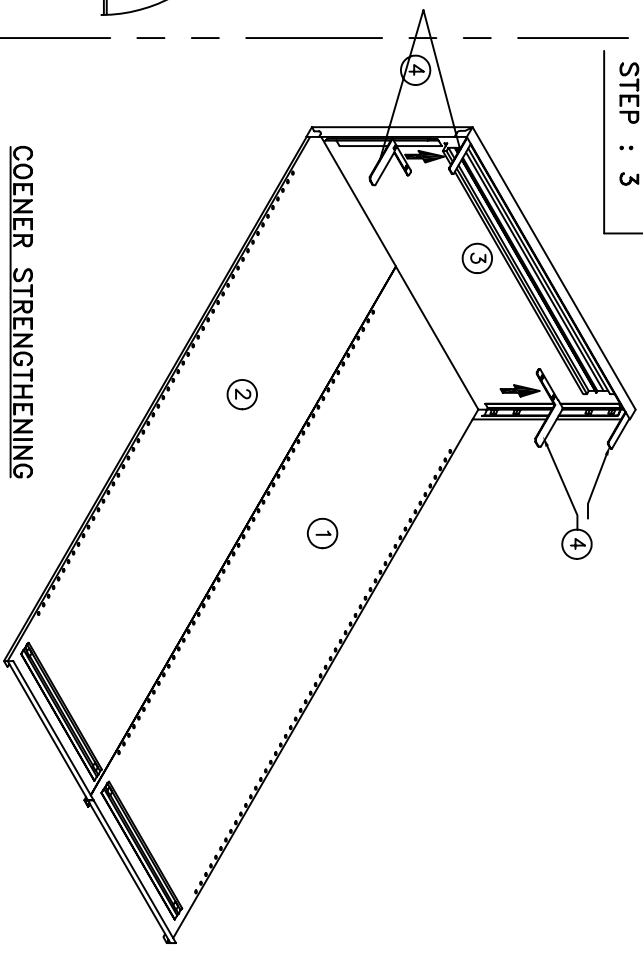

COENER STRENGTHENING  
PIECE ASSEMBLY WITH TOP

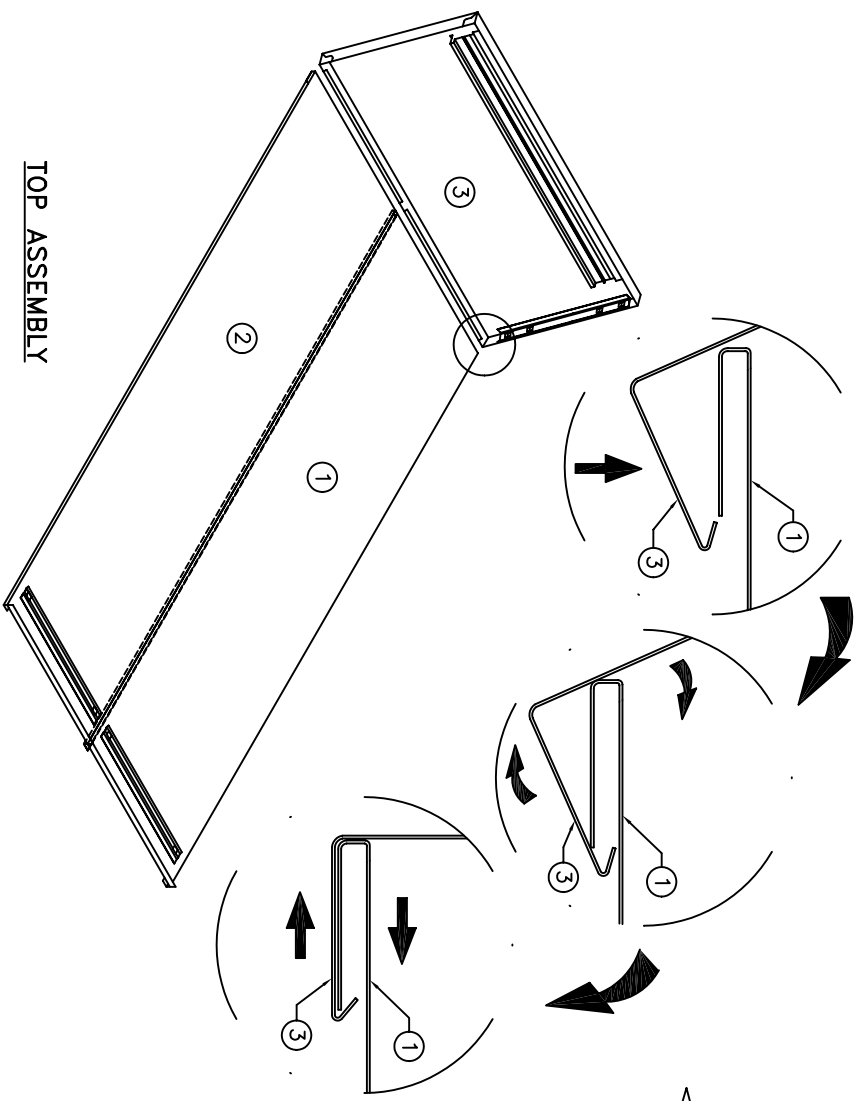

TOP ASSEMBLY

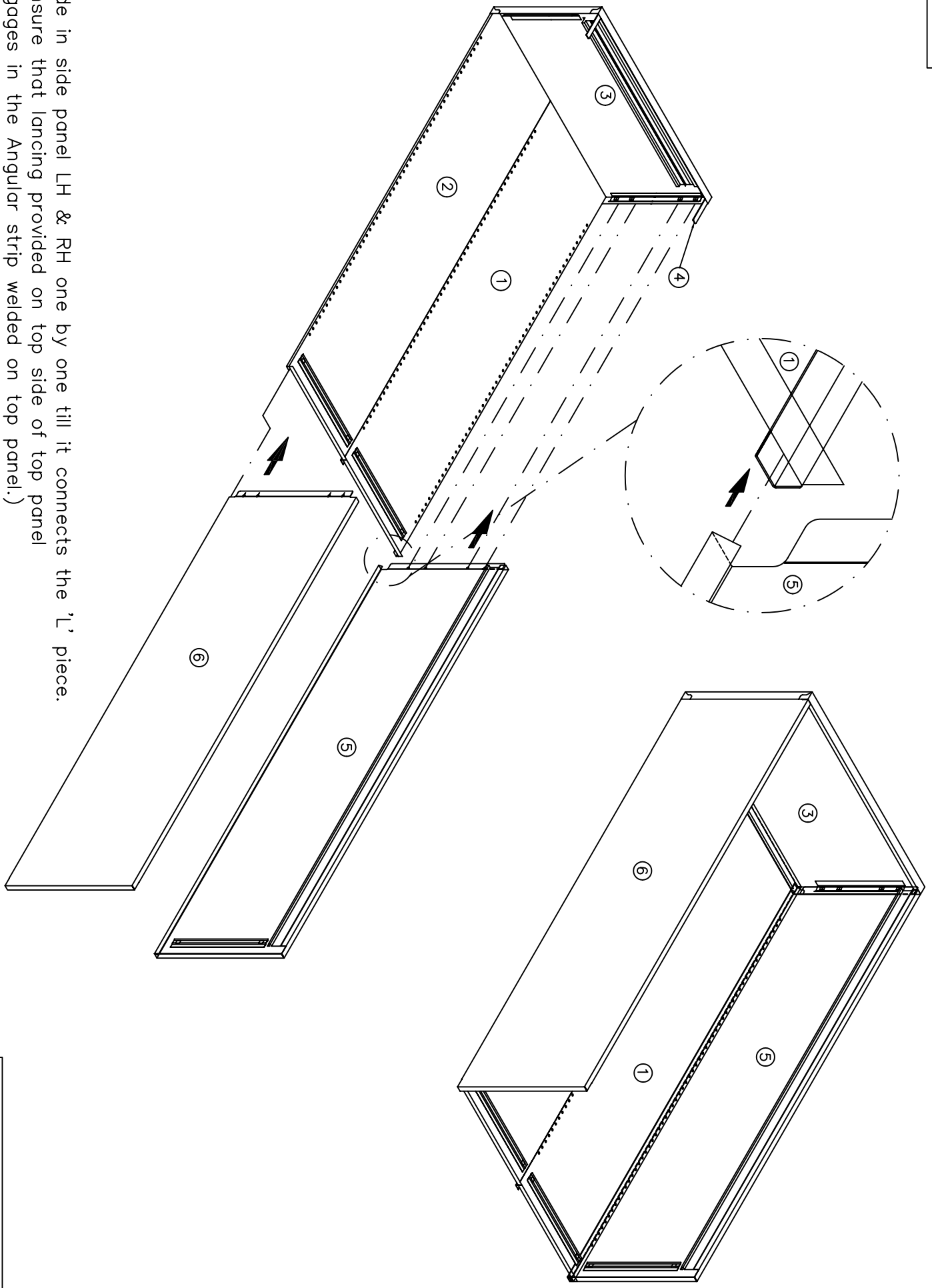

Slide in side panel LH & RH one by one till it connects the 'L' piece.  
(Ensure that lancing provided on top side of top panel engages in the Angular strip welded on top panel.)

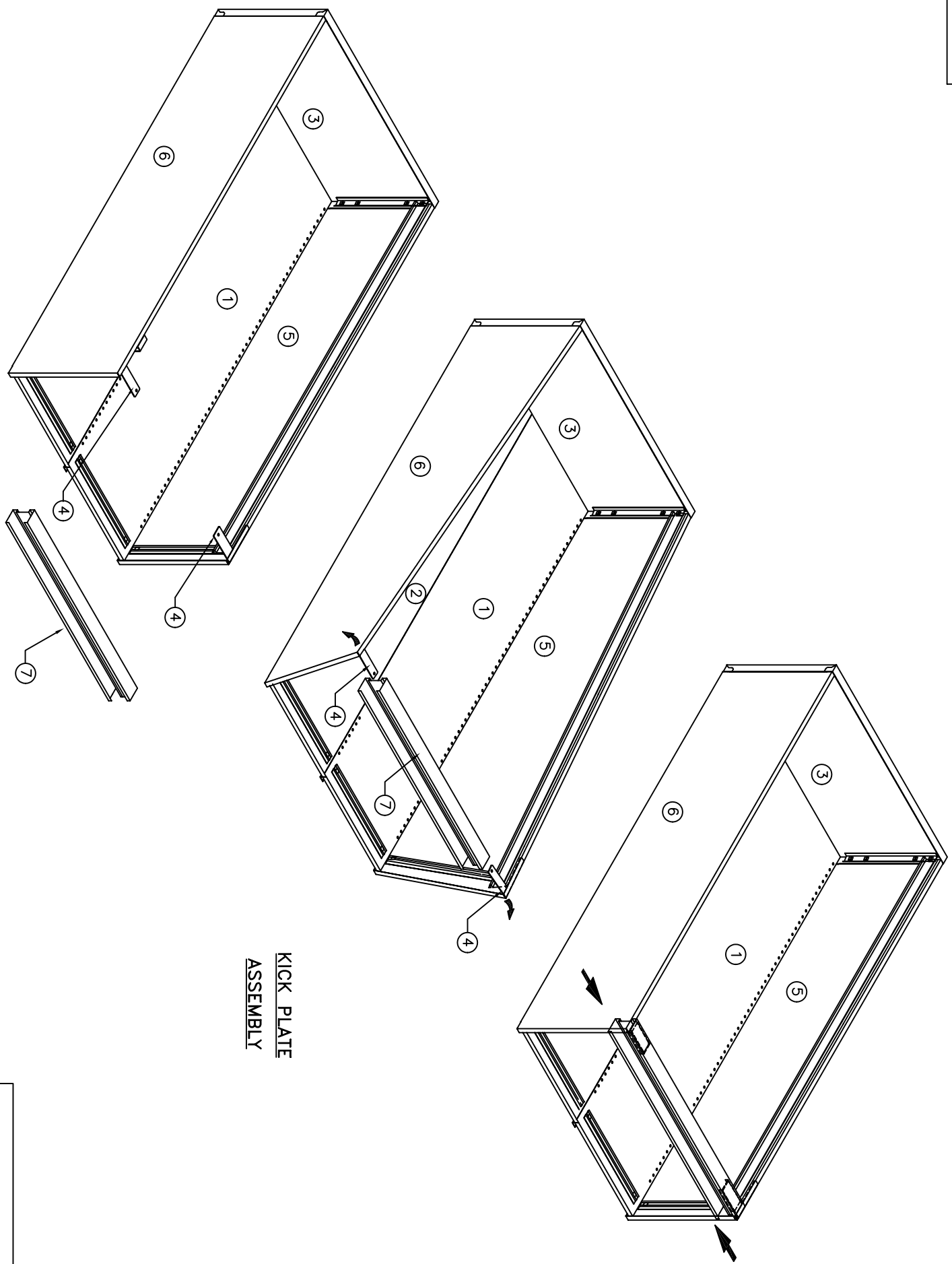

KICK PLATE  
ASSEMBLY

STEP : 6

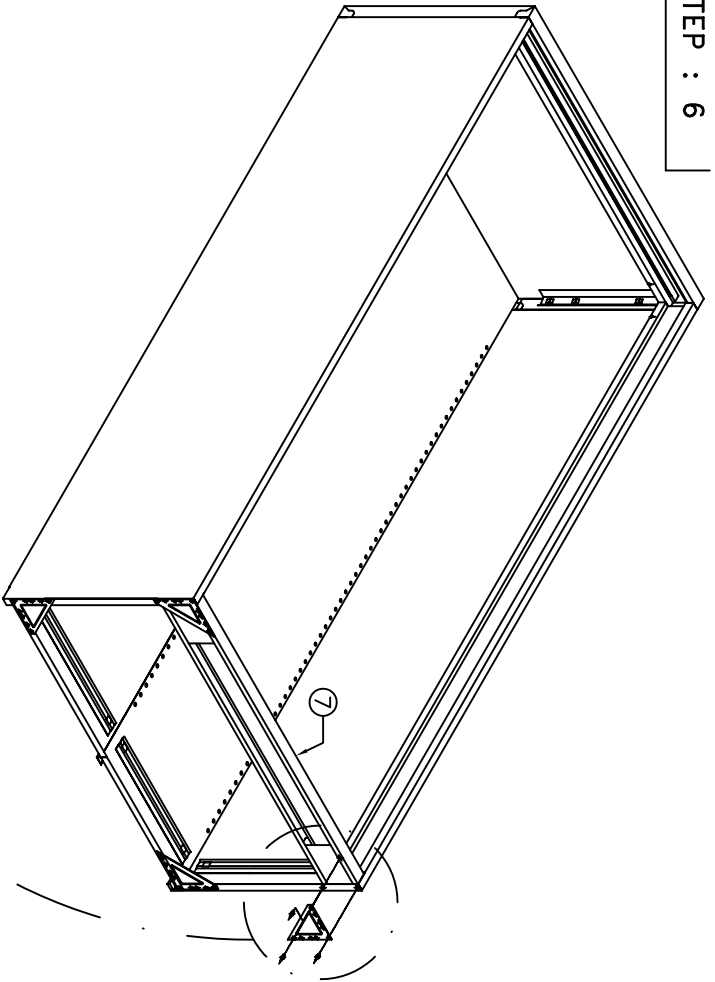

Pop-rivet four bottom corner pieces as shown in the figure.

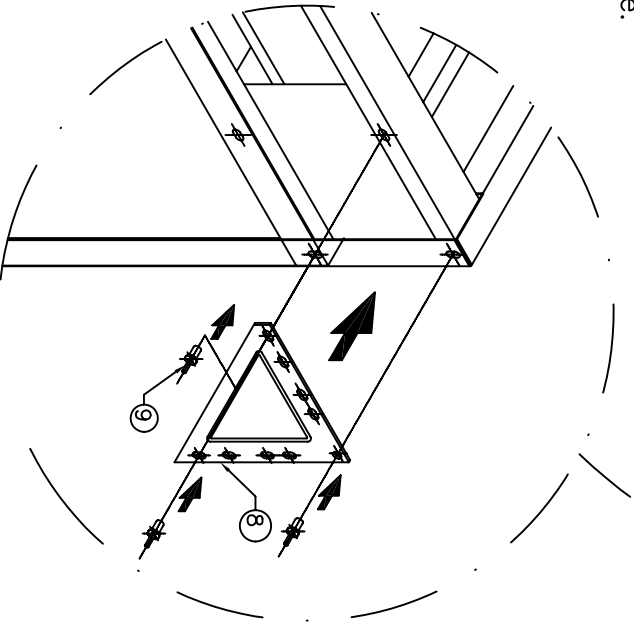

STEP : 7

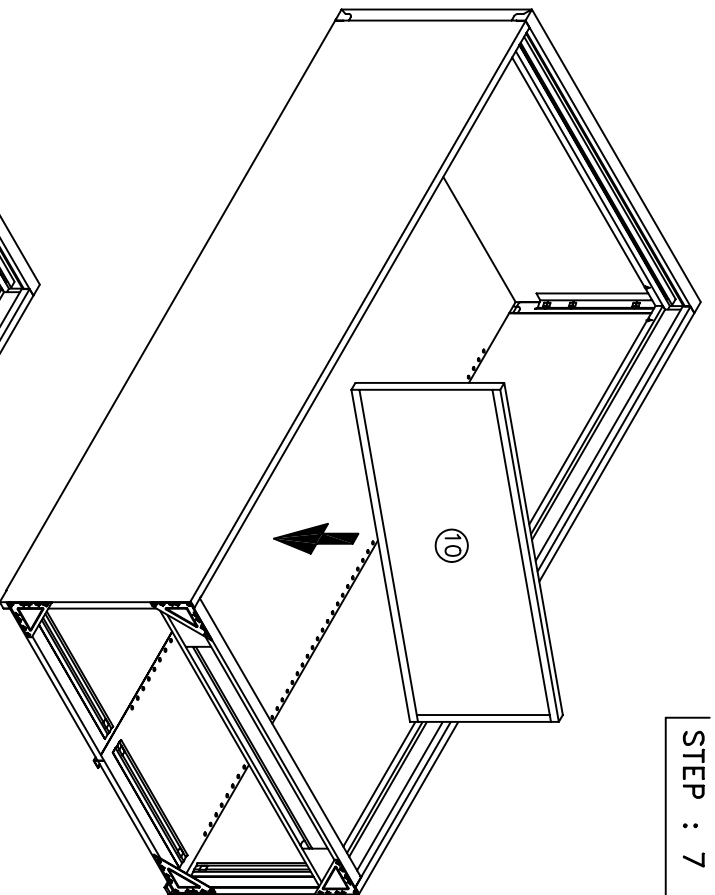

Insert bottom panel as shown in the figure.

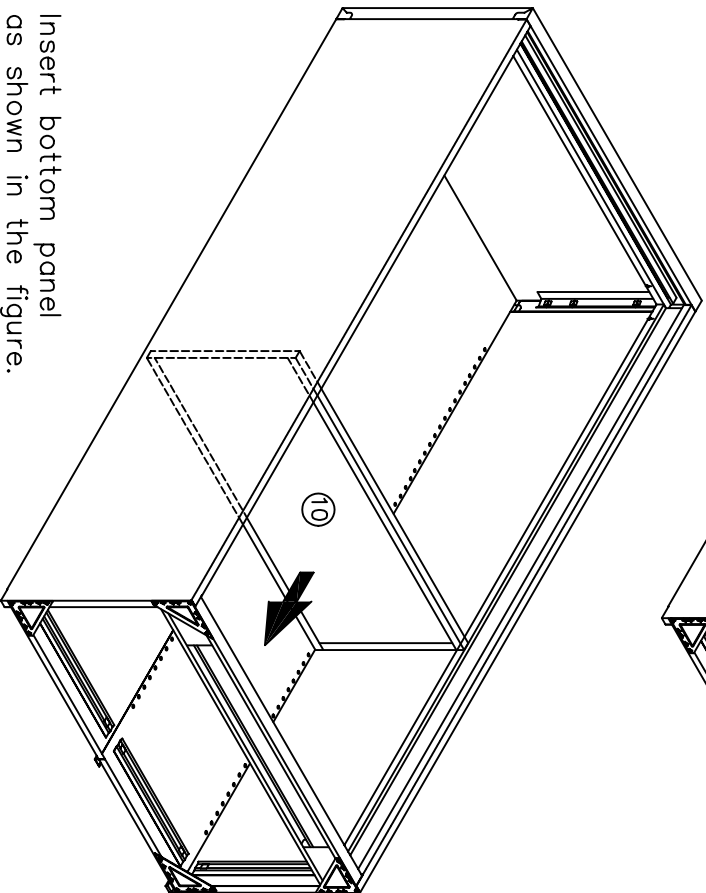

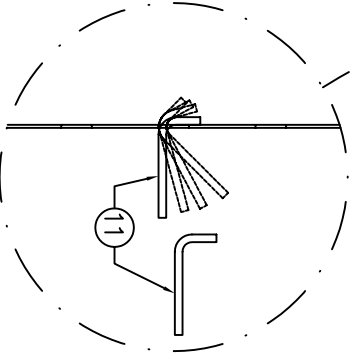
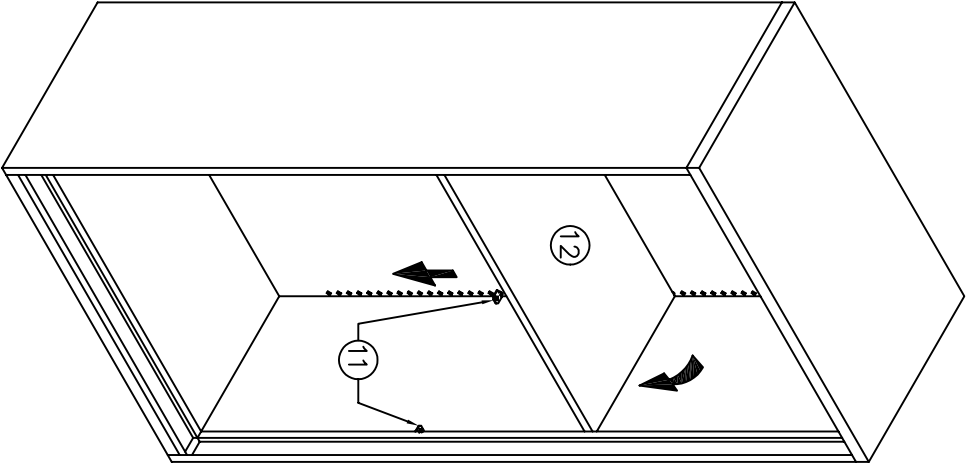
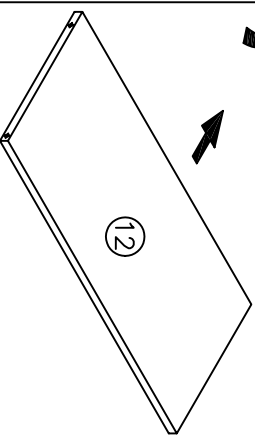
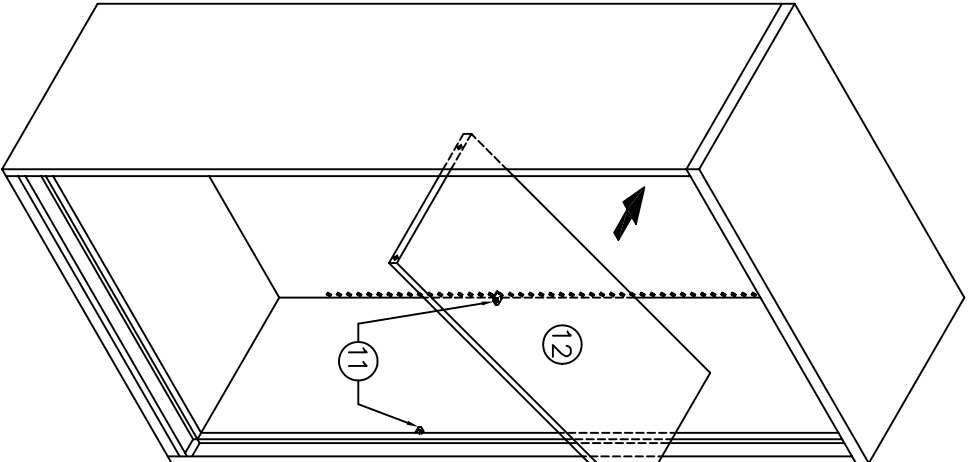
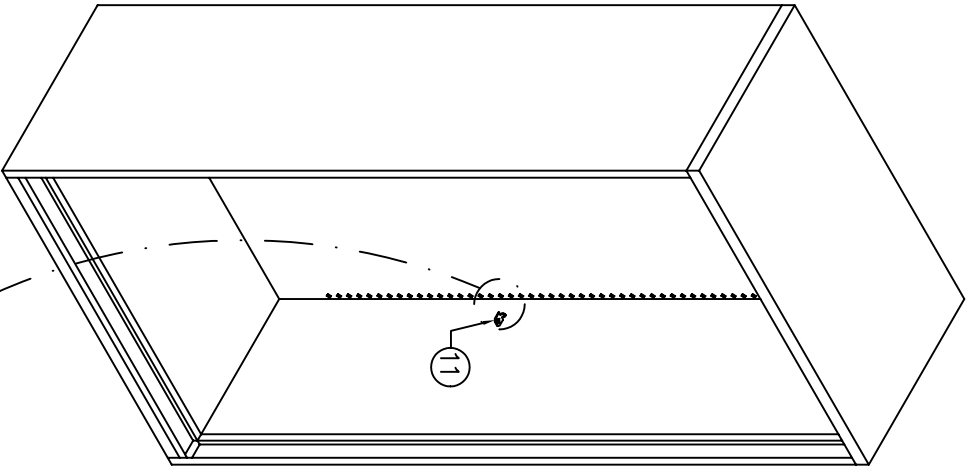

Insert shelf support at appropriate height in back panel & side stiffener.  
Place shelf on shelf support.

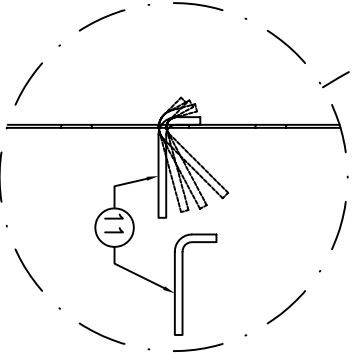
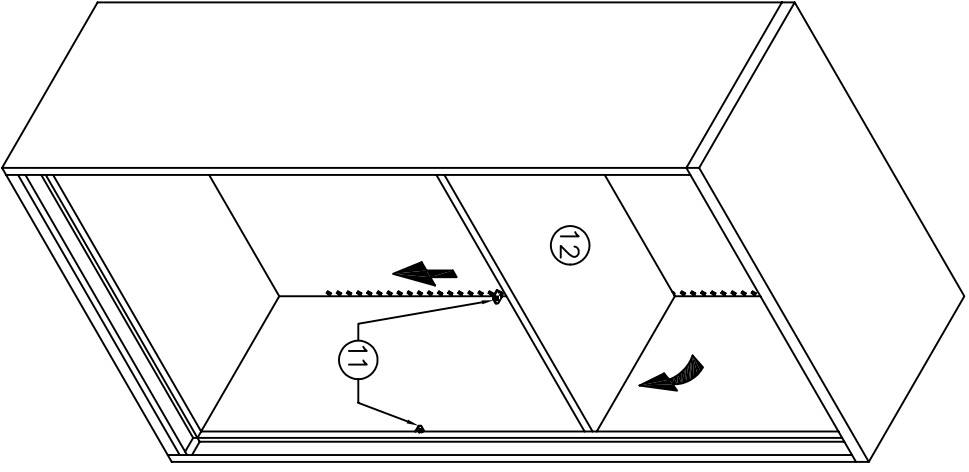
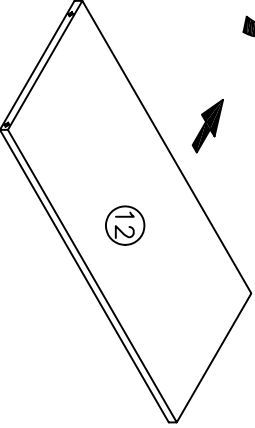
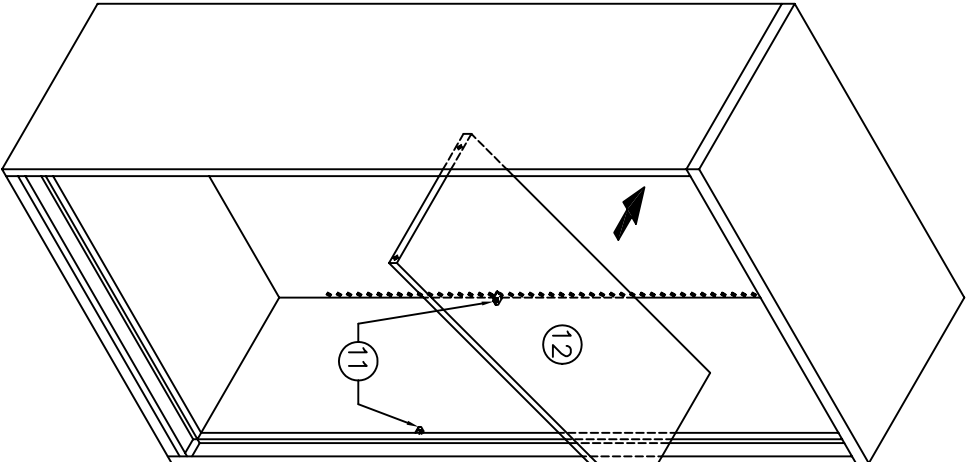
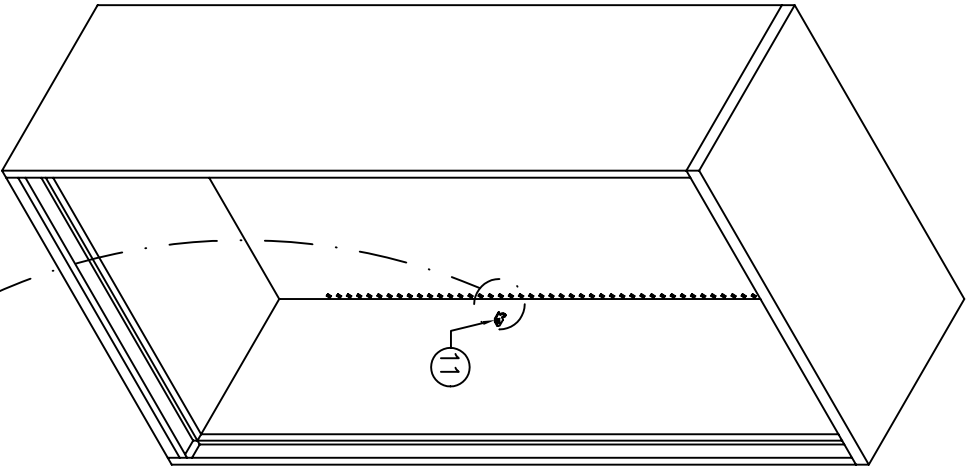

Insert shelf support at appropriate height in back panel & side stiffener.  
Place shelf on shelf support.

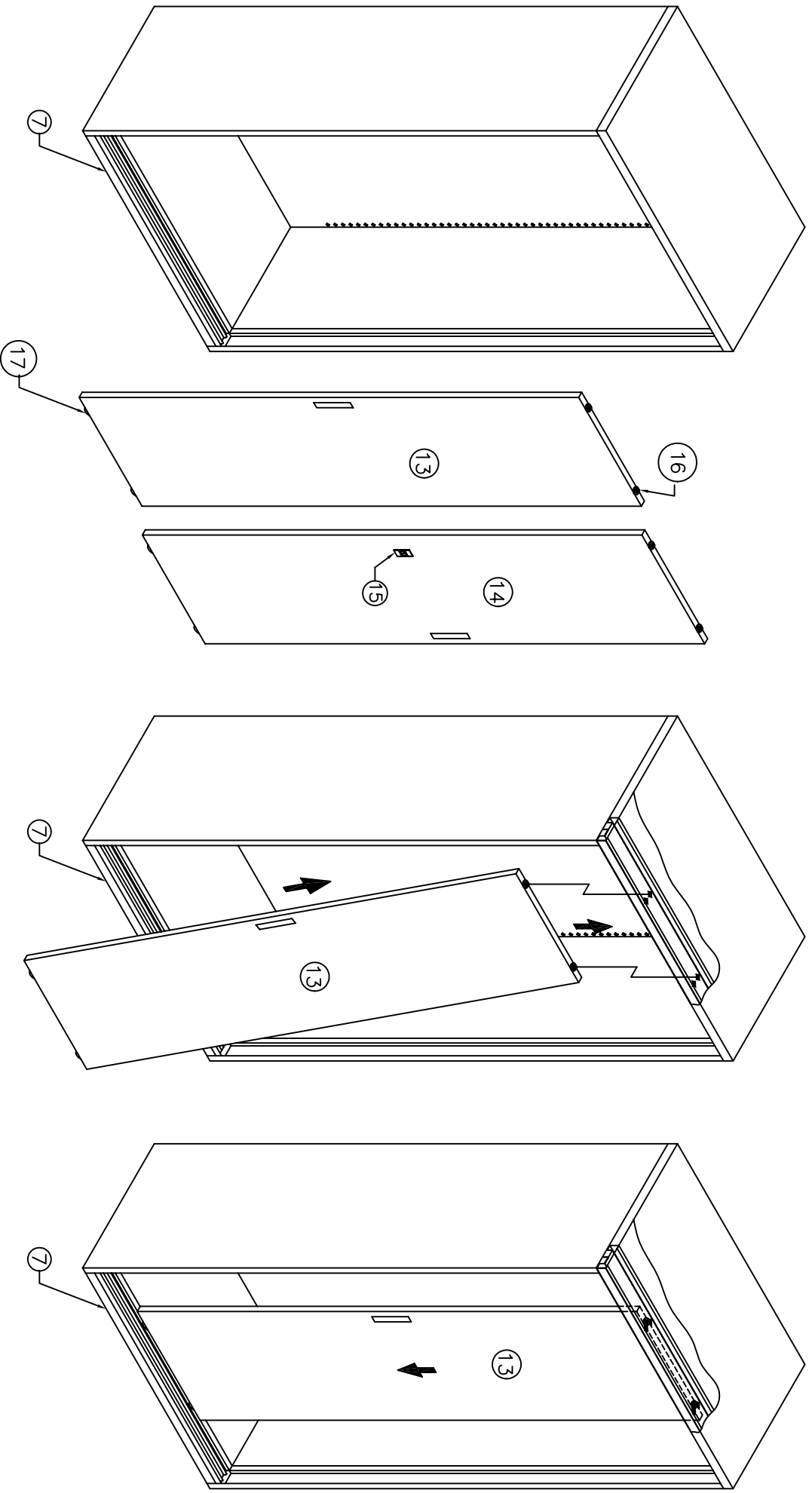

Insert door LH in the body assembly by passing the top roller in to the holes provided at the center of the top stiffener. Lower the door by locating the bottom rollers on the door rail. (Check smooth sliding of door.)



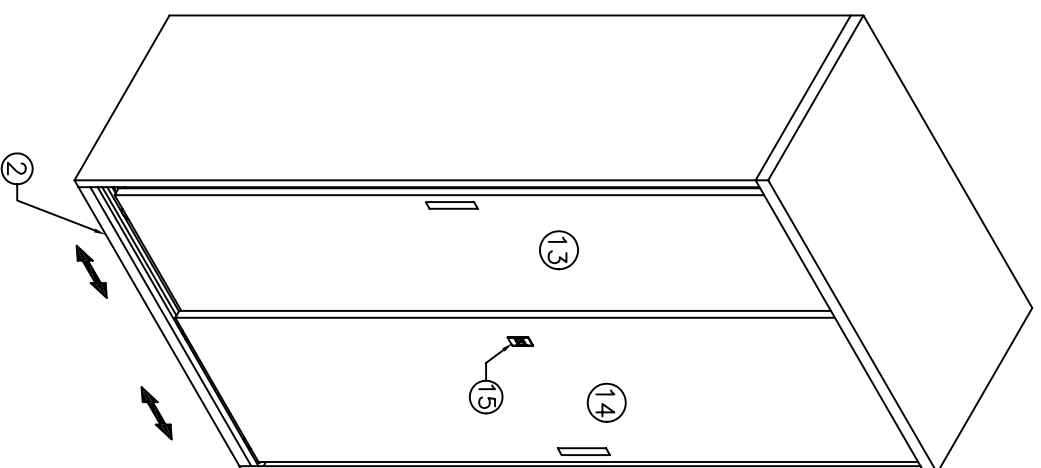
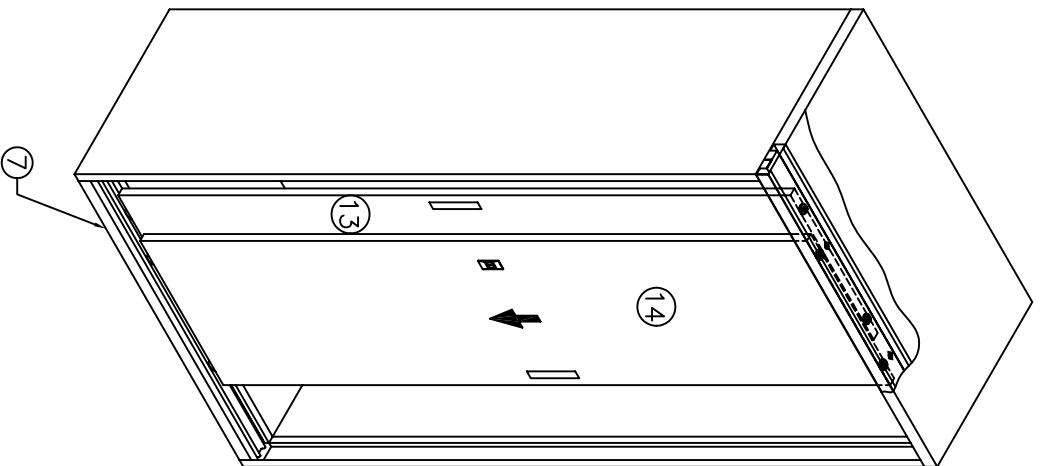
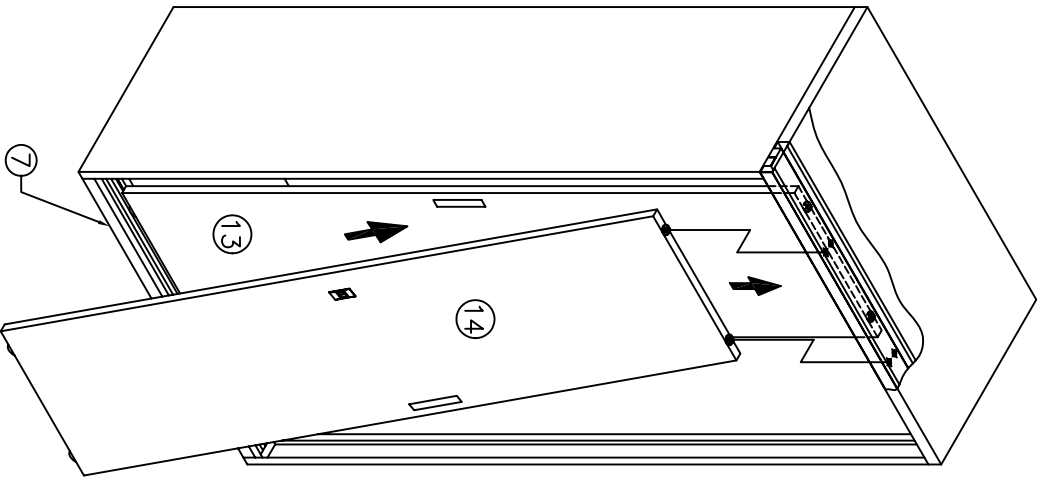

Insert door RH in the body assembly by passing the top roller in to the holes provided at the center of the top stiffener. Lower the door by locating the bottom rollers on the door rail. (Check smooth sliding and proper locking of the doors.)