

Lateral Filing Cabinet

Our lateral filing cabinets provide ergonomic features that are sturdy and aesthetically designed to provide a comprehensive filing solution.

All drawers are mounted on ball bearing slides which are smooth and easy to operate.

The drawers extend fully for convenient access to the entire drawer.

The cabinets can accommodate legal and letter size files.



Certified in 2022
in USA







Lateral Filing Cabinet

MODEL	DRAWERS	PAPER SIZE	DOOR OPTIONS	H (in)	W (in)	D (in)
LFC 2 (30")	2	Legal (LS) Letter (LES)		28.0	30.0	18.2
LFC 2 (36")	2	Legal (LS) Letter (LES)		28.0	36.0	18.2
LFC 2 (42")	2	Legal (LS) Letter (LES)		28.0	42.0	18.2
LFC 3 (30")	3			40.0	30.0	18.2
LFC 3 (36")	3	Legal (LS) Letter (LES)		40.0	36.0	18.2
LFC 3 (42")	3	Legal (LS) Letter (LES)		40.0	42.0	18.2
LFC 4 (30")	4	Legal (LS) Letter (LES)		52.0	30.0	18.2
LFC 4 (36")	4	Legal (LS) Letter (LES)		52.0	36.0	18.2
LFC 4 (42")	4	Legal (LS) Letter (LES)		52.0	42.0	18.2
LFC 5 (30")	5	Legal (LS) Letter (LES)		64.0	30.0	18.2
LFC 5 (36")	5	Legal (LS) Letter (LES)		64.0	36.0	18.2
LFC 5 (42")	5	Legal (LS) Letter (LES)		64.0	42.0	18.2
LFC 4 FUD 1	4	Legal (LS) Letter (LES)	1 Flip-Up Door (FUD)	64.0	36.0	18.2

Heights shown above are without leveling glides.

Lateral Filing Cabinet





KEY FEATURES

- Limited lifetime warranty, per conditions
- Durable steel structure
- 66 lbs and 110 lbs ball bearing slides for uniformly distributed load for each drawer
- Drawers operate on full extension precision ball slides for smooth movement
- A file bar and a hanging folder rail are provided in each drawer to accommodate legal and letter size files for side-to-side or for front-to-back filing
- Full-height drawer sides and back to provide additional storage capacity and added strength
- Full-extension drawers for convenient access to the entire drawer
- Anti-tilt design allows one drawer to be opened at a time preventing the cabinet from tipping over. The anti-tilt locking mechanism is interlinked on both sides and therefore two drawers cannot be opened together at the same time (product must be placed on level ground)
- Anti-rebound mechanism prevents drawer from coming out again after it is pushed in
- Counter-weight is provided for each lateral filing cabinet
- Leveling glides are included at the bottom of the cabinet, at the four corners, to allow for adjustment on uneven floor surfaces and for floor protection
- Central cam lock controlling all drawers at both ends
- Core-removable locks can be provided on request
- Master keys can be supplied for all locks
- Locks have 3,000 combinations
- PVC, metal or formed label holder for each drawer can be supplied on request
- Alternate gauges of steel are available

HANDLE OPTIONS



Rectangular Recessed handle RH



Swan neck Recessed handle SNH

LOCK



Cam Lock

OPTIONAL ACCESSORIES



PVC Label Holder



Leveling Glide

LFC Filing Arrangements

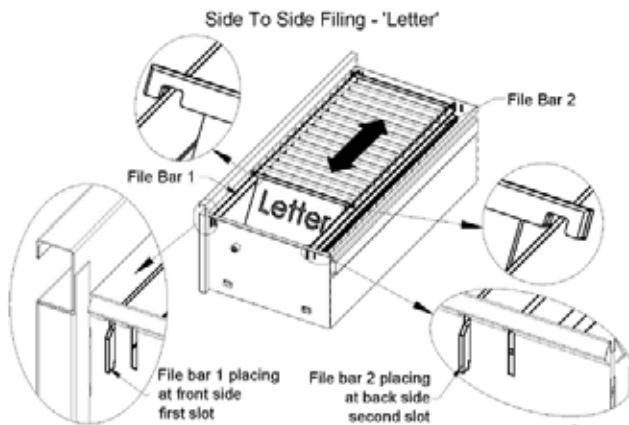

LFC Filing Arrangements

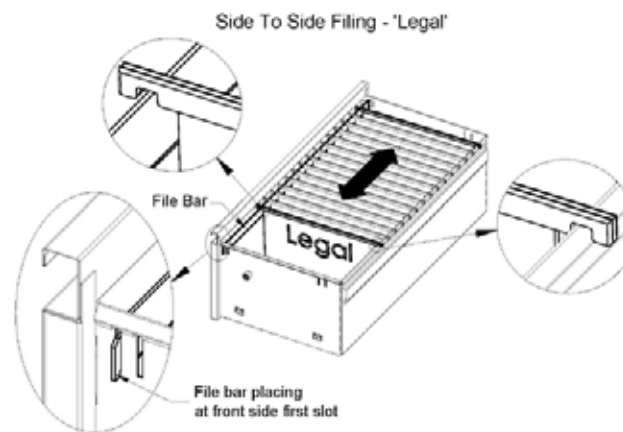

LFC Filing Arrangements

